

AXOR

DE / Gebrauchsanleitung / Montageanleitung	02
FR / Mode d'emploi / Instructions de montage	03
EN / Instructions for use / assembly instructions	04
IT / Istruzioni per l'uso / Istruzioni per l'installazione	05
ES / Modo de empleo / Instrucciones de montaje	06
NL / Gebruiksaanwijzing / Handleiding	07
DK / Brugsanvisning / Monteringsvejledning	08
PT / Instruções para uso / Manual de Instalação	09
PL / Instrukcja obsługi / Instrukcja montażu	10
CS / Návod k použití / Montážní návod	11
SK / Návod na použitie / Montážny návod	12
RU / Руководство пользователя / Инструкция по монтажу	14
HU / Használati útmutató / Szerelési útmutató	15
FI / Käyttöohje / Asennusohje	16
SV / Bruksanvisning / Monteringsanvisning	17
LT / Vartotojo instrukcija / Montavimo instrukcijos	18
HR / Upute za uporabu / Uputstva za instalaciju	19
TR / Kullanım kılavuzu / Montaj kılavuzu	20
RO / Manual de utilizare / Instrucțiuni de montare	21
EL / Οδηγίες χρήσης / Οδηγία συναρμολόγησης	22
SL / Navodilo za uporabo / Navodila za montažo	23
ET / Kasutusjuhend / Paigaldusjuhend	24
LV / Lietošanas pamācība / Montāžas instrukcija	25
SR / Uputstvo za upotrebu / Uputstvo za montažu	26
NO / Bruksanvisning / Montasjeveiledning	27
BG / Инструкция за употреба / Ръководство за монтаж	28
SQ / Udhëzuesi i përdorimit / Udhëzime rreth montimit	29
AR / دليل الاستخدام / تعليمات التجميع	30

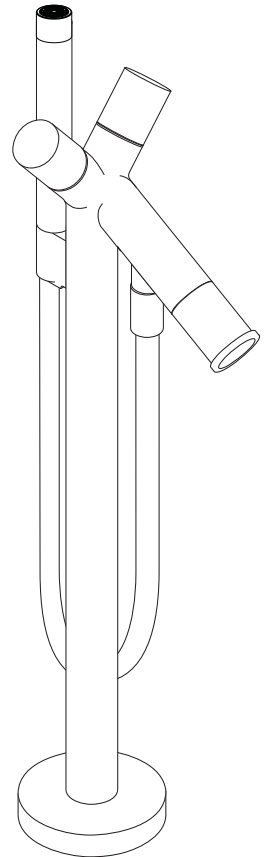

AXOR Starck
10458000

INSTALLATION

⚠ SICHERHEITSHINWEISE

- ⚠ Bei der Montage müssen zur Vermeidung von Quetsch- und Schnittverletzungen Handschuhe getragen werden.
- ⚠ Das Produkt darf nur zu Bade-, Hygiene- und Körperreinigungszwecken eingesetzt werden.
- ⚠ Kinder, sowie Erwachsene mit körperlichen, geistigen und/oder sensorischen Einschränkungen dürfen das Produkt nicht unbeaufsichtigt benutzen. Personen, die unter Alkohol- oder Drogeneinfluss stehen, dürfen das Produkt nicht benutzen.
- ⚠ Der Kontakt der Brausestrahlen mit empfindlichen Körperstellen (z. B. Augen) muss vermieden werden. Es muss ein ausreichender Abstand zwischen Brause und Körper eingehalten werden.
- ⚠ Das Produkt darf nicht als Haltegriff benutzt werden. Es muss ein separater Haltegriff montiert werden.
- ⚠ Große Druckunterschiede zwischen den Kalt- und Warmwasseranschlüssen müssen ausgeglichen werden.

MONTAGEHINWEISE

- / Vor der Montage muss das Produkt auf Transportschäden untersucht werden. Nach dem Einbau werden keine Transport- oder Oberflächenschäden anerkannt.
- / Die Leitungen und die Armatur müssen nach den gültigen Normen montiert, gespült und geprüft werden.
- / Die in den Ländern jeweils gültigen Installationsrichtlinien sind einzuhalten.
- / Die der Brause beige packte Siebdichtung muss eingebaut werden, um Schmutzeinspülungen aus dem Leitungsnetz zu vermeiden. Schmutzeinspülungen können die Funktion beeinträchtigen und/oder zu Beschädigungen an Funktionsteilen der Brause führen, für hieraus ergebende Schäden haftet Hansgrohe nicht.

TECHNISCHE DATEN

Betriebsdruck:	max. 1 MPa
Empfohlener Betriebsdruck:	0,1 - 0,5 MPa
Prüfdruck:	1,6 MPa
	(1 MPa = 10 bar = 147 PSI)
Heißwassertemperatur:	max. 70°C
Empfohlene Heißwassertemperatur:	65°C
Thermische Desinfektion:	max. 70°C / 4 min

- / Eigensicher gegen Rückfließen
- / Das Produkt ist ausschließlich für Trinkwasser konzipiert!



MONTAGE (siehe Seite 31)

SYMBOLERKLÄRUNG



Kein essigsäurehaltiges Silikon verwenden!



MA SSE (siehe Seite 33)



Badewanne freistehend mit Außenverkleidung.



DURCHFLUSSDIAGRAMM (siehe Seite 34)

- ① Handbrause
- ② Auslauf



REINIGUNG (siehe Seite 38)



WARTUNG (siehe Seite 36)

- / Rückflussverhinderer müssen gemäß DIN EN 1717 regelmäßig in Übereinstimmung mit nationalen oder regionalen Bestimmungen auf ihre Funktion geprüft werden (mindestens einmal jährlich).



BEDIENUNG (siehe Seite 35)



SERVICETEILE (siehe Seite 37)

SONDERZUBEHÖR
(nicht im Lieferumfang enthalten)



/ Verlängerung 60 mm #97686000 (siehe Seite 37)



/ Verlängerung 60 mm #10981000 (siehe Seite 37)



/ Verlängerung 20 mm #10983000 (siehe Seite 37)



/ Montageschlüssel #58085000 (siehe Seite 32+37)

△ CONSIGNES DE SÉCURITÉ

- △ Lors du montage, porter des gants de protection pour éviter toute blessure par écrasement ou coupure.
- △ Le produit ne doit servir qu'à se laver et à assurer l'hygiène corporelle.
- △ Il est interdit aux enfants ainsi qu'aux adultes ayant des insuffisances physiques, psychiques et/ou motoriques d'utiliser la douche sans surveillance. De même, il est interdit à des personnes sous influence d'alcool ou de drogues d'utiliser la douche.
- △ Éviter le contact du jet de la douchette avec les parties sensibles du corps (telles par ex. que les yeux). Veiller à respecter un écart suffisant entre la douchette et le corps
- △ Le produit ne doit pas servir de poignée. Monter pour cela une poignée séparée.
- △ Il est conseillé d'équilibrer les pressions de l'eau chaude et froide.

INSTRUCTIONS POUR LE MONTAGE

- / Avant son montage, s'assurer que le produit n'a subi aucun dommage pendant le transport. Après le montage, tout dommage de transport ou de surface ne pourra pas être reconnu.
- / Les conduites et la robinetterie doivent être montés, rincés et contrôlés selon les normes en vigueur.
- / Les directives d'installation en vigueur dans le pays concerné doivent être respectées.
- / Le joint à filtre fourni avec la pomme de douche à main doit être installé afin de retenir des impuretés du système de conduites. Ceux-ci pourraient influencer le fonctionnement de ce produit et même endommager des pièces mobiles. Des réclamations à la suite de l'usage de la pomme de douche sans joint-tamis de hansgrohe ne peuvent pas faire partie de notre garantie.

INFORMATIONS TECHNIQUES

Pression de service autorisée:	max. 1 MPa
Pression de service conseillée:	0,1 - 0,5 MPa
Pression maximum de contrôle:	1,6 MPa
	(1 MPa = 10 bar = 147 PSI)
Température d'eau chaude:	max. 70°C
Température recommandée:	65°C
Désinfection thermique:	max. 70°C / 4 min

- / Avec dispositif anti-retour
- / Le produit est exclusivement conçu pour de l'eau potable!

DESCRIPTION DU SYMBOLE

-  Ne pas utiliser de silicone contenant de l'acide acétique!
-  DIMENSIONS (voir pages 33)
-  Baignoire autonome avec tablier lesion.
-  DIAGRAMME DU DÉBIT (voir pages 34)
 - ① Douchette
 - ② bec
-  NETTOYAGE (voir pages 38)
-  ENTRETIEN (voir pages 36)
 - / Les clapets anti-retour doivent être examinés régulièrement conformément à la norme EN 1717 ou conformément aux dispositions nationales ou régionales quant à leur fonction (au moins une fois par an).
-  INSTRUCTIONS DE SERVICE (voir pages 35)
-  PIÈCES DÉTACHÉES (voir pages 37)
- ACCESSOIRES EN OPTION (ne fait pas partie de la fourniture)
 -  / jeu de rallonge 60 mm #97686000 (voir pages 37)
 -  / jeu de rallonge 60 mm #10981000 (voir pages 37)
 -  / jeu de rallonge 20 mm #10983000 (voir pages 37)
 -  / clé de montage #58085000 (voir pages 32+37)



MONTAGE (voir pages 31)

△ SAFETY NOTES

- △ Gloves should be worn during installation to prevent crushing and cutting injuries.
- △ The product may only be used for bathing, hygienic and body cleaning purposes.
- △ Children as well as adults with physical, mental and/or sensoric impairments must not use this product without proper supervision. Persons under the influence of alcohol or drugs are prohibited from using this product.
- △ Do not allow the streams of the shower touch sensitive body parts (such as your eyes). An adequate distance must be kept between the shower and you.
- △ The product may not be used as a holding handle. A separate handle must be installed.
- △ The hot and cold supplies must be of equal pressures.

INSTALLATION INSTRUCTIONS

- / Prior to installation, inspect the product for transport damages. After it has been installed, no transport or surface damage will be honoured.
- / The pipes and the fixture must be installed, flushed and tested as per the applicable standards.
- / The plumbing codes applicable in the respective countries must be observed.
- / The mesh washer must be insert to protect the shower against incoming dirt by pipework. Incoming dirt leads to defects or/and can damage parts of the shower; such caused faults voids all liability and guarantee claims.

TECHNICAL DATA

Operating pressure:	max. 1 MPa
Recommended operating pressure:	0,1 - 0,5 MPa
Test pressure:	1,6 MPa
	(1 MPa = 10 bar = 147 PSI)
Hot water temperature:	max. 70°C
Recommended hot water temp.:	65°C
Thermal disinfection:	max. 70°C / 4 min

- / Safety against backflow
- / The product is exclusively designed for drinking water!

SYMBOL DESCRIPTION



Do not use silicone containing acetic acid!



DIMENSIONS (see page 33)



Freestanding tub with outside covering.



FLOW DIAGRAM (see page 34)

① Hand shower

② spout



CLEANING (see page 38)



MAINTENANCE (see page 36)

- / The check valves must be checked regularly according to DIN EN 1717 in accordance with national or regional regulations (at least once a year).



OPERATION (see page 35)



SPARE PARTS (see page 37)

SPECIAL ACCESSORIES

(order as an extra)



/ extension 60 mm #97686000 (see page 37)



/ extension 60 mm #10981000 (see page 37)



/ extension 20 mm #10983000 (see page 37)



/ special tool #58085000 (see page 32+37)



ASSEMBLY (see page 31)

△ INDICAZIONI SULLA SICUREZZA

- △ Durante il montaggio, per evitare ferite da schiacciamento e da taglio bisogna indossare guanti protettivi.
- △ Il prodotto deve essere utilizzato esclusivamente per fare il bagno e per l'igiene del corpo.
- △ I bambini e gli adulti affetti da menomazioni fisiche, psichiche e/o sensoriali devono utilizzare il sistema doccia solo sotto sorveglianza. Il prodotto non deve essere utilizzato da persone sotto l'effetto di droghe o alcolici.
- △ Bisogna evitare il contatto fra il getto della doccia e parti del corpo delicate (ad es. gli occhi). Fra il soffione ed il corpo va mantenuta una distanza sufficiente.
- △ Il prodotto non deve essere utilizzato come maniglia, questa deve essere montata separatamente.
- △ Attenzione! Compensare le differenze di pressione tra i collegamenti dell'acqua fredda e dell'acqua calda.

ISTRUZIONI PER IL MONTAGGIO







- / Prima del montaggio è necessario controllare che non ci siano stati danni durante il trasporto. Una volta eseguito il montaggio, non verranno riconosciuti eventuali danni di trasporto o delle superfici.
- / Montare, lavare e controllare tubature e rubinetteria rispettando le norme correnti.
- / Vanno rispettate le direttive di installazione nazionali vigenti nel rispettivo paese.
- / Per proteggere la soffione doccia da eventuali impurità provenienti dalle tubazioni dell'acqua, deve essere inserito il filtro nell'impugnatura della doccia stessa. Tali impurità possono infatti causare difetti e/o danneggiare parti della doccia; in questo caso la Hansgrohe non risponde dei danni.

DATI TECNICI

Pressione d'uso:	max. 1 MPa
Pressione d'uso consigliata:	0,1 - 0,5 MPa
Pressione di prova:	1,6 MPa (1 MPa = 10 bar = 147 PSI)
Temperatura dell'acqua calda:	max. 70°C
Temp. dell'acqua calda consigliata:	65°C
Disinfezione termica:	max. 70°C / 4 min

- / Sicurezza antiriflusso
- / Il prodotto è concepito esclusivamente per acqua potabile!





DESCRIZIONE SIMBOLO

-  Non utilizzare silicone contenente acido acetico!
-  INGOMBRI (vedi pagg. 33)
-  Autoportante con rivestimento esterno.
-  DIAGRAMMA FLUSSO (vedi pagg. 34)
 - ① Doccetta
 - ② bocca erogazione
-  PULITURA (vedi pagg. 38)
-  MANUTENZIONE (vedi pagg. 36)
 - / La valvola di non ritorno deve essere controllata regolarmente come da DIN EN 1717, secondo le normative nazionali e regionali (almeno una volta all'anno).

-  PROCEDURA (vedi pagg. 35)

-  PARTI DI RICAMBIO (vedi pagg. 37)

ACCESSORI SPECIALI (non contenuto nel volume di fornitura)

-  / prolunga 60 mm #97686000 (vedi pagg. 37)
-  / prolunga 60 mm #10981000 (vedi pagg. 37)
-  / prolunga 20 mm #10983000 (vedi pagg. 37)
-  / chiave per montaggio #58085000 (vedi pagg. 32+37)



MONTAGGIO (vedi pagg. 31)

△ INDICACIONES DE SEGURIDAD

- △ Durante el montaje deben utilizarse guantes para evitar heridas por aplastamiento o corte.
- △ El producto solo debe ser utilizado para fines de baño, higiene y limpieza corporal.
- △ Niños, así como adultos con limitaciones corporales, mentales y/o sensoriales no deben utilizar el sistema de duchas sin vigilancia. Personas que se encuentran bajo el efecto de alcohol o drogas, no deben utilizar el sistema de duchas.
- △ Debe evitarse el contacto del chorro del pulverizador con partes sensibles del cuerpo (por ej. ojos). Debe mantenerse una distancia suficiente entre pulverizador y cuerpo.
- △ El producto no debe ser utilizado como un elemento de sujeción. Debe montarse un elemento de sujeción separado.
- △ Grandes diferencias de presión en servicio entre agua fría y agua caliente deben equilibrarse.

INDICACIONES PARA EL MONTAJE

- / Antes del montaje se debe examinarse el producto contra daños de transporte. Después de la instalación no se reconoce ningún daño de transporte o de superficie.
- / Los conductos y la grifería deben montarse, lavarse y comprobarse según las normas vigentes.
- / Es obligatorio el cumplimiento de las directrices de instalación vigentes en el país respectivo.
- / La junta de filtración que se suministra con la ducha mural evita que las partículas de suciedad procedentes de las tuberías lleguen a la ducha mural. Debe colocarse entre el flexo y la ducha mural. Infiltraciones de suciedad deterioran el funcionamiento de la ducha mural y pueden causar daños en el interior de la misma que no están cubiertas por la garantía de Hansgrohe.

DATOS TÉCNICOS

Presión en servicio:	max. 1 MPa
Presión recomendada en servicio:	0,1 - 0,5 MPa
Presión de prueba:	1,6 MPa
	(1 MPa = 10 bar = 147 PSI)
Temperatura del agua caliente:	max. 70°C
Temp. recomendada del agua caliente:	65°C
Desinfección térmica:	max. 70°C/4 min

- / Seguro contra el retorno
- / El producto ha sido concebido exclusivamente para agua potable.



MONTAJE (ver página 31)

DESCRIPCIÓN DE SÍMBOLOS



No utilizar silicona que contiene ácido acético!



DIMENSIONES (ver página 33)



De pie con revestimiento exterior.



DIAGRAMA DE CIRCULACIÓN
(ver página 34)

- ① Teleducha
- ② Caño



LIMPIAR (ver página 38)



MANTENIMIENTO (ver página 36)

- / Las válvulas anti-retorno tienen que ser controladas regularmente según la norma DIN EN 1717, en acuerdo con las regulaciones nacionales o regionales (una vez al año, por lo menos).



MANEJO (ver página 35)



REPUESTOS (ver página 37)

OPCIONAL (no incluido en el suministro)



/ Prolongación 60 mm #97686000 (ver página 37)



/ Prolongación 60 mm #10981000 (ver página 37)



/ Prolongación 20 mm #10983000 (ver página 37)



/ Llave de montaje #58085000 (ver página 32+37)

△ VEILIGHEIDSLINSTRUCTIES

- △ Bij de montage moeten ter voorkoming van knel- en snijwonden handschoenen worden gedragen.
- △ Het product mag alleen voor het wassen, hygiënische doeleinden en voor de lichaamsreiniging worden gebruikt.
- △ Kinderen en volwassenen met lichamelijke, geestelijke en/of sensorische beperkingen mogen het douchesysteem niet zonder toezicht gebruiken. Personen onder invloed van alcohol of drugs mogen het douchesysteem niet gebruiken.
- △ Het contact van de douchestraal met gevoelige lichaamsdelen (bijv. ogen) moet worden voorkomen. Er moet voldoende afstand tussen douche en lichaam aangehouden worden.
- △ Het product mag niet als handgreep worden gebruikt. Er moet een aparte handgreep gemonteerd worden.
- △ Grote drukverschillen tussen de koud- en warmwater-toevoer dienen vermeden te worden.

MONTAGE-INSTRUCTIES

- / Vóór de montage moet het product gecontroleerd worden op transportschade. Na de inbouw wordt geen transport- of oppervlakteschade meer aanvaard.
- / De leidingen en armaturen moeten gemonteerd, gespoeld en gecontroleerd worden volgens de geldige normen.
- / De in de overeenkomstige landen geldende installatierichtlijnen moeten nageleefd worden.
- / Het bij de hoofddouche verpakte zeefje moet worden ingebouwd om vuil uit de waterleiding te weren. Vuil uit de leidingen kan de werking van de hoofddouche negatief beïnvloeden en/of de hoofddouche beschadigen. Voor deze schade is Hansgrohe niet verantwoordelijk.

TECHNISCHE GEGEVENS

Werkdruk: max.	max. 1 MPa
Aanbevolen werkdruk:	0,1 - 0,5 MPa
Getest bij:	1,6 MPa
	(1 MPa = 10 bar = 147 PSI)
Temperatuur warm water:	max. 70°C
Aanbevolen warm water temp.:	65°C
Thermische desinfectie:	max. 70°C / 4 min

- / Beveiligd tegen terugstromen
- / Het product is uitsluitend ontworpen voor drinkwater!

SYMBOOLBESCHRIJVING

-  Gebruik geen zuurhoudende silicone!
-  MATEN (zie blz. 33)
-  Vrijstaand badkuip met buitenmantel.
-  DOORSTROOMDIAGRAM (zie blz. 34)
 - ① Handdouche
 - ② uitloop
-  REINIGEN (zie blz. 38)
-  ONDERHOUD (zie blz. 36)
 - / Keerkleppen moeten volgens DIN EN 1717 regelmatig en volgens plaatselijk geldende eisen op het functioneren gecontroleerd worden. (Tenminste een keer per jaar)

-  BEDIENING (zie blz. 35)

-  SERVICE ONDERDELEN (zie blz. 37)

- TOEBEHOREN (behoort niet tot het leveringspakket)
 - / Verlengstuk 60 mm #97686000 (zie blz. 37)
 -  / Verlengstuk 60 mm #10981000 (zie blz. 37)
 -  / Verlengstuk 20 mm #10983000 (zie blz. 37)
 -  / montagesleutel #58085000 (zie blz. 32+37)

△ SIKKERHEDSANVISNINGER

- △ Ved monteringen skal der bruges handsker for at undgå kvæstelser og snitsår.
- △ Produktet må kun bruges til bade-, hygiejne og kropsurengøringsformål.
- △ Børn som også voksne med fysiske, mentale og/eller sensoriske begrænsninger må ikke bruge brusersystemet uden opsyn. Personer som er under indflydelse af alkohol eller narkotika må ikke bruge brusersystemet.
- △ Bruserstrålens kontakt med sensitive områder (f.eks. øjne) skal undgås. Der skal være en tilstrækkelig afstand mellem bruseren og kroppen.
- △ Produktet må ikke bruges som håndtag. Der skal monteres et separat håndtag.
- △ Større trykforskelle mellem koldt og varmt vand bør undgås.

MONTERINGSANVISNINGER

- / Før monteringen skal produktet kontrolleres for transportskader. Efter monteringen godkendes transportskader eller skader på overfladen ikke længere.
- / Ledningerne og armaturerne skal monteres, skylles og kontrolleres iht. de gældende standarder.
- / Installationsbestemmelserne, der gælder i det enkelte land, skal overholdes.
- / Den vedlagte smudsfangssi skal indsættes i bruseren for at undgå snavs fra rørsystemet. Indskyllet snavs kan have indflydelse på bruserens funktion og/eller føre til beskadigelser på håndbruserens funktionsdele.

TEKNISKE DATA

Driftstryk:	max. 1 MPa
Anbefalet driftstryk:	0,1 - 0,5 MPa
Prøvetryk:	1,6 MPa
	(1 MPa = 10 bar = 147 PSI)
Varmtvandstemperatur:	max. 70°C
Anbefalet varmtvandstemperatur:	65°C
Termisk desinfektion:	max. 70°C / 4 min

- / Med indbygget kontraventil
- / Produktet er udelukkende beregnet til drikkevand!

SYMBOLBESKRIVELSE



Der må ikke benyttes eddikesyreholdig silikone!



MÅLENE (se s. 33)



Fritstående badekar, med udvendig beklædning.



GENNEMSTRØMNINGSDIAGRAM
(se s. 34)

- ① Håndbruser
- ② Udløb



RENGØRING (se s. 38)



SERVICE (se s. 36)

/ Ifølge DIN EN 1717 skal gennemstrømningsbegrænsere i overensstemmelse med nationale regler afprøves regelmæssigt (mindst en gang om året).



BRUGSANVISNING (se s. 35)



RESERVEDELE (se s. 37)

SPECIALTILBEHØR
(ikke med i leveringsomfang)



/ Forlængersæt 60 mm #97686000 (se s. 37)



/ Forlængersæt 60 mm #10981000 (se s. 37)



/ Forlængersæt 20 mm #10983000 (se s. 37)



/ Monteringsnøgle #58085000 (se s. 32+37)



MONTERING (se s. 31)

⚠ AVISOS DE SEGURANÇA

- ⚠ Durante a montagem devem ser utilizadas luvas de protecção, de modo a evitar ferimentos resultantes de entalamentos e de cortes.
- ⚠ O produto só pode ser utilizado para fins de higiene pessoal.
- ⚠ Crianças e adultos com deficiências motoras, mentais e/ou sensoriais não podem utilizar o sistema de duche sem monitorização. Pessoas que estejam sob a influência de álcool ou drogas não podem utilizar o sistema de duche.
- ⚠ Deve-se evitar o contacto dos jactos de água com partes do corpo sensíveis (p. ex. olhos). É necessário manter uma distância suficiente entre o chuveiro e o corpo.
- ⚠ O produto não pode ser utilizado como pega de apoio. Tem que ser montada uma pega separada.
- ⚠ Grandes diferenças entre as pressões das águas quente e fria devem ser compensadas.

AVISOS DE MONTAGEM







- / Antes da montagem deve-se controlar o produto relativamente a danos de transporte. Após a montagem não são aceites quaisquer danos de transporte ou de superfície.
- / As tubagens e a torneira têm que ser montadas, enxaguadas e verificadas de acordo com as normas em vigor.
- / A prescrições de instalação válidas nos respetivos países devem ser respeitadas.
- / O filtro de rede deve ser colocado para proteger o chuveiro de areias e resíduos provenientes da tubagem. Resíduos e areias podem danificar componentes, ou provocar mau funcionamento do chuveiro; as avarias assim provocadas anulam a nossa responsabilidade e anulam a nossa garantia.

DADOS TÉCNICOS





Pressão de funcionamento:	max. 1 MPa
Pressão de func. recomendada:	0,1 - 0,5 MPa
Pressão testada:	1,6 MPa
	(1 MPa = 10 bar = 147 PSI)
Temperatura da água quente:	max. 70°C
Temp. água quente recomendada:	65°C
Desinfecção térmica:	max. 70°C / 4 min

- / Função anti-retorno e anti-vácuo
- / Este produto foi única e exclusivamente concebido para água potável!

DESCRIÇÃO DO SÍMBOLO

-  Não utilizar silicone que contenha ácido acético!
-  MEDIDAS (ver página 33)
-  Banheira de pé com revestimento externo.
-  FLUXOGRAMA (ver página 34)
 - ① Chuveiro de mão
 - ② Bica
-  LIMPEZA (ver página 38)
-  MANUTENÇÃO (ver página 36)
 - / As válvulas anti-retorno devem ser verificadas regularmente de acordo com a DIN EN 1717 segundo os regulamentos nacionais ou regionais (pelo menos uma vez por ano).

-  FUNCIONAMENTO (ver página 35)

-  PEÇAS DE SUBSTITUIÇÃO (ver página 37)
- ACESSÓRIOS ESPECIAIS (não incluído no volume de fornecimento)
 -  / Crescente 60 mm #97686000 (ver página 37)
 -  / Crescente 60 mm #10981000 (ver página 37)
 -  / Crescente 20 mm #10983000 (ver página 37)
 -  / Chave especial #58085000 (ver página 32+37)

△ WSKAZÓWKI BEZPIECZEŃSTWA

- △ Aby uniknąć zranień na skutek zgniecenia lub przecięcia, podczas montażu należy nosić rękawice ochronne.
- △ Produkt może być używany tylko do kąpieli, higieny i czyszczenia ciała.
- △ Zarówno dzieci, jak i dorośli z fizycznymi, psychicznymi i/lub sensorycznymi ograniczeniami nie mogą korzystać z prysznica bez opieki. Osoby znajdujące się pod wpływem alkoholu lub narkotyków nie mogą korzystać z prysznica.
- △ Należy unikać kontaktu strumienia wyływającego z głowicy z wrażliwymi częściami ciała (np. oczami). Należy zachowywać odpowiednią odległość pomiędzy głowicą a ciałem.
- △ Produktu nie wolno używać jako uchwytu do trzymania się. Należy zamontować osobny uchwyt.
- △ Znaczne różnice ciśnień na dopływach ciepłej i zimnej wody muszą zostać wyrównane.

WSKAZÓWKI MONTAŻOWE













- / Przed montażem należy skontrolować produkt pod kątem szkód transportowych. Po montażu nie widać żadnych szkód transportowych ani szkód na powierzchni.
- / Przewody i armatura muszą być montowane, płukane i kontrolowane według obowiązujących norm.
- / Należy przestrzegać wytycznych instalacyjnych obowiązujących w danym kraju.
- / Znajdujące się przy prysznicu sitko musi zostać zainstalowane, aby zatrzymać zanieczyszczenia z instalacji. Przedostające się zanieczyszczenia mogą mieć ujemny wpływ na działanie i/lub prowadzić do usterek w działaniu elementów prysznica. Za powstałe z tego tytułu szkody firma Hansgrohe nie ponosi odpowiedzialności.

DANE TECHNICZNE

Ciśnienie robocze:	maks. 1 MPa
Zalecane ciśnienie robocze:	0,1 - 0,5 MPa
Ciśnienie próbne:	1,6 MPa
	(1 MPa = 10 bary = 147 PSI)
Temperatura wody gorącej:	maks. 70°C
Zalecana temperatura wody gorącej:	65°C
Dezynfekcja termiczna:	maks. 70°C / 4 min

- / Zabezpieczony przed przepływem zwrotnym
- / Produkt przeznaczony wyłącznie do wody pitnej!

OPIS SYMBOLU

-  Nie stosować silikonów zawierających kwas octowy!
-  WYMIARY (patrz strona 33)
-  Wolno stojąca wanna z obudową.
-  SCHEMAT PRZEPŁYWU (patrz strona 34)
 - ① Prysznic ręczny
 - ② Wylot
-  CZYSZCZENIE (patrz strona 38)
-  KONSERWACJA (patrz strona 36)
 - / Zgodnie z normą DIN EN 1717, krajowymi i miejscowymi przepisami, działanie zabezpieczeń przed przepływem zwrotnym musi być kontrolowane (przynajmniej raz w roku).
-  OBSŁUGA (patrz strona 35)
-  CZĘŚCI SERWISOWE (patrz strona 37)
- WYPOSAŻENIE SPECJALNE (Nie jest częścią dostawy)
 -  / Przedłużka 60 mm #97686000 (patrz strona 37)
 -  / Przedłużka 60 mm #10981000 (patrz strona 37)
 -  / Przedłużka 20 mm #10983000 (patrz strona 37)
 -  / Klucz montażowy #58085000 (patrz strona 32+37)



MONTAŻ (patrz strona 31)

△ BEZPEČNOSTNÍ POKYNY

- △ Pro zabránění řezným zraněním a pohmožděninám je nutné při montáži nosit rukavice.
- △ Produkt smí být používán pouze ke koupání a za účelem tělesné hygieny.
- △ Děti a dospělí osoby s tělesným, duševním a/ nebo smyslovým postižením nesmí produkt používat bez dozoru. Osoby pod vlivem alkoholu nebo drog nesmí produkt používat.
- △ Je nutné zabránit kontaktu vodních paprsků sprchy s měkkými částmi těla (např. očima). Je nutné dodržovat dostatečný odstup mezi sprchou a tělem.
- △ Produkt nesmí být používán jako madlo. Je nutné namontovat samostatné madlo.
- △ Je nutné vyrovnat velké rozdíly tlaku mezi přípoji studené a teplé vody.

POKYNY K MONTÁŽI

- / Před montáží je třeba produkt zkontrolovat, zda nebyl při transportu poškozen. Po zabudování nebudou uznány žádné škody způsobené transportem nebo poškození povrchu.
- / Vedení a armatura musí být namontovány, propláchnuty a otestovány podle platných norem.
- / Je třeba dodržovat montážní pravidla platné v dané zemi.
- / Do přívodu musí být zabudováno se sprchou dodávané sítko, aby zachycovalo nečistoty vyplavené z vodovodní sítě. Vyplavené nečistoty mohou ovlivnit funkci sprchy a nebo mohou vést i k jejímu poškození. Na takto vzniklé škody se nevztahuje záruka firmy Hansgrohe.

TECHNICKÉ ÚDAJE

Provozní tlak:	max. 1 MPa
Doporučený provozní tlak:	0,1 - 0,5 MPa
Zkušební tlak:	1,6 MPa
	(1 MPa = 10 bar = 147 PSI)
Teplota horké vody:	max. 70°C
Doporučená teplota horké vody:	65°C
Teplná desinfekce:	max. 70°C / 4 min

- / Vlastní jištění proti zpětnému nasátí.
- / Výrobky Hansgrohe jsou vhodné pro přímý kontakt s pitnou vodou.

POPIS SYMBOLŮ

 Nepoužívat silikon s obsahem kyseliny octové!

 ROZMĚRY (viz strana 33)

 Volně stojící vana s vnějším obložením.

 DIAGRAM PRŮTOKU (viz strana 34)
 ① Ruční sprcha
 ② výtok

 ČIŠTĚNÍ (viz strana 38)

 ÚDRŽBA (viz strana 36)

- / U zpětných ventilů se musí podle DIN EN 1717 v souladu s národními nebo regionálními předpisy testovat jejich funkčnost (alespoň jednou ročně).

 OVLÁDÁNÍ (viz strana 35)

 SERVISNÍ DÍLY (viz strana 37)

ZVLÁŠTNÍ PŘÍSLUŠENSTVÍ
(není součástí dodávky)

 / prodloužení 60 mm #97686000 (viz strana 37)

 / prodloužení 60 mm #10981000 (viz strana 37)

 / prodloužení 20 mm #10983000 (viz strana 37)

 / montážní klíč #58085000 (viz strana 32+37)



MONTÁŽ (viz strana 31)

△ BEZPEČNOSTNÉ POKYNY

- △ Pri montáži musíte nosiť rukavice, aby ste predišli pomliaždeninám a rezným poraneniam.
- △ Produkt sa smie používať len na kúpanie a telesnú hygienu.
- △ Produkt nesmú bez dozoru používať deti, ako aj dospelé osoby s telesným, duševným a/alebo zmyslovým postihnutím. Produkt nesmú používať ani osoby, ktoré sú pod vplyvom alkoholu alebo drog.
- △ Vyhýbajte sa kontaktu vodného lúča sprchy s citlivými miestami tela (napr. oči). Dodržiavajte dostatočnú vzdialenosť medzi sprchou a telom.
- △ Výrobok sa nesmie používať ako držadlo. K tomu účelu sa musí namontovať samostatné držadlo.
- △ Veľké rozdiely v tlaku medzi prípojkami studenej a teplej vody musia byť vyrovnané.

POKYNY PRE MONTÁŽ













- / Pred montážou musíte produkt skontrolovať, či nebol počas transportu poškodený. Po zabudovaní nebudú uznané žiadne škody spôsobené transportom alebo poškodenia povrchu.
- / Ledningarna och blandaren måste monteras, spolás igenom och kontrolleras enligt de gällande normerna.
- / Je potrebné dodržiavať smernice o inštalácii, ktoré sú práve teraz platné v krajinách.
- / Do prívodu musí byť zabudované so sprchou dodávané sítko, aby zachytilo nečistoty vyplavené z vodovodnej siete. Vyplavené nečistoty môžu ovplyvniť funkciu sprchy, alebo spôsobiť jej poškodenie. Na takto vzniknuté škody sa nevzťahuje záruka firmy Hansgrohe.

TECHNICKÉ ÚDAJE

Prevádzkový tlak:	max. 1 MPa
Doporučený prevádzkový tlak:	0,1 - 0,5 MPa
Skúšobný tlak:	1,6 MPa
	(1 MPa = 10 bar = 147 PSI)
Teplota teplej vody:	max. 70°C
Doporučená teplota teplej vody:	65°C
Termická dezinfekcia:	max. 70°C / 4 min

- / Vlastná poistka proti spätnému nasatiu.
- / Výrobok je koncipovaný výhradne pre pitnú vodu!

POPIS SYMBOLOV

-  Nepoužívať silikón s obsahom kyseliny octovej!
-  ROZMERY (viď strana 33)
-  Voľne stojaca vaňa s vonkajším opláštením.
-  DIAGRAM PRIETOKU (viď strana 34)
 - ① Ručná sprcha
 - ② odpad
-  ČISTENIE (viď strana 38)
-  ÚDRŽBA (viď strana 36)
 - / Pri spätných ventiloch sa musí podľa DIN EN 1717 v súlade s národnými alebo regionálnymi predpismi testovať ich funkčnosť (aspoň raz ročne).
-  OBSLUHA (viď strana 35)
-  SERVISNÉ DIELY (viď strana 37)
- ZVLÁŠTNE PRÍSLUŠENSTVO (nie je súčasťou dodávky)
 -  / Predĺženie 60 mm #97686000 (viď strana 37)
 -  / Predĺženie 60 mm #10981000 (viď strana 37)
 -  / Predĺženie 20 mm #10983000 (viď strana 37)
 -  / montážny kľúč #58085000 (viď strana 32+37)



MONTÁŽ (viď strana 31)

△ 安全技巧

- △ 装配时为避免挤压和切割受伤，必须戴上手套。
- △ 本产品只允许作为洗浴、卫生和洁身之用。
- △ 不得让儿童和肢体、精神和/或意识有障碍的成人在不受监管的情况下使用淋浴系统。受酒精或毒品影响的人员不得使用淋浴系统。
- △ 必须避免让身体敏感部位（如眼睛）接触到莲蓬头喷水。必须保持莲蓬头与人头之间有足够的距离。
- △ 该产品不得作扶柄使用。必须安装单独的扶柄。
- △ 冷热水管间过大的压力差必须予以平衡。

安装提示













- / 安装前必须检查产品是否受到运输损害。安装后将不认可运输损害或表面损伤。
- / 管道和阀门必须根据通用标准进行安装、冲洗和检查。
- / 请遵守当地国家现行的安装规定。
- / 必须装上花洒所自带的滤网密封垫，以过滤管道里的杂质污物。杂质污物会影响花洒的功能和或损坏花洒的功能部件，由此而产生的产品损坏不属于汉斯格雅的保修范围。

技术参数

工作压强:	最大 1 MPa
推荐工作压强:	0,1 - 0,5 MPa
测试压强:	1,6 MPa
	(1 MPa = 10 bar = 147 PSI)
热水温度:	最大 70°C
推荐热水温度:	65°C
热力消毒:	最大 70°C / 4 分钟

- / 自动防止回流
- / 该产品专为饮用水设计！

符号说明

-  请勿使用含有乙酸的硅胶！
-  大小 (参见第 33)
-  独立式浴盆及外罩。
-  流量示意图 (参见第 34)
 - ① 手持花洒
 - ② 水嘴套件
-  清洗 (参见第 38)
-  保养 (参见第 36)
 - / 单向阀必须在符合国家或当地的法律的情况下按照 DIN EN 1717 定期检查 (至少一年一次)。
-  操作 (参见第 35)
-  备用零件 (参见第 37)
- 选装附件 (不在供货范围内)
 -  / 加长件 60 mm #97686000 (参见第 37)
 -  / 加长件 60 mm #10981000 (参见第 37)
 -  / 加长件 20 mm #10983000 (参见第 37)
 -  / 专用工具 #58085000 (参见第 32+37)

△ УКАЗАНИЯ ПО ТЕХНИКЕ БЕЗОПАСНОСТИ

- △ Во время монтажа следует надеть перчатки во избежание прищемления и порезов.
- △ Изделие разрешается использовать только в гигиенических целях: для принятия ванны и личной гигиены.
- △ Дети, а также взрослые с физическими, умственными и/или сенсорными недостатками должны пользоваться изделием только под присмотром. Запрещается пользоваться изделием в состоянии алкогольного или наркотического опьянения.
- △ Не допускайте попадания струи воды из разбрызгивателя на чувствительные части тела (например, на глаза). Разбрызгиватель следует устанавливать на достаточном расстоянии от тела.
- △ Изделие запрещается использовать в качестве рукоятки. Следует устанавливать специальную рукоятку.
- △ донного клапа. Перед установкой смесителя необходимо регулировочными кранами выровнять давление холодной и горячей воды при помощи вентилей регулирующих подачу воды в квартиру.

УКАЗАНИЯ ПО МОНТАЖУ

- / Перед монтажом следует проверить изделие на предмет повреждений при перевозке. После монтажа претензии о возмещении ущерба за повреждения при перевозке или повреждения поверхностей не принимаются.
- / Трубы и арматура должны быть установлены, промыты и проверены в соответствии с действующими нормами.
- / Необходимо соблюдать требования по монтажу, действующие в соответствующих странах.
- / Для предотвращения попадания частиц грязи из водопроводной сети необходимо установить фильтр, прилагаемый к ручному душу. Частицы грязи могут нарушить отдельные функции и/или привести к повреждению функциональных деталей ручного душа, Hansgrohe не несет ответственность за повреждения вследствие отсутствия фильтра.

ТЕХНИЧЕСКИЕ ДАННЫЕ

Рабочее давление:	не более, 1 МПа
Рекомендуемое рабочее давление:	0,1 - 0,5 МПа
Давления:	1,6 МПа
	(1 МПа = 10 bar = 147 PSI)
Температура горячей воды:	не более, 70°C
Рекомендуемая темп. гор. воды:	65°C
Термическая дезинфекция:	не более, 70°C/4 мин

- / укомплектован клапаном обратного тока воды
- / Изделие предназначено исключительно для питьевой воды!



МОНТАЖ (см. стр. 31)

ОПИСАНИЕ СИМВОЛОВ



Не применяйте силикон, содержащий уксусную кислоту.



РАЗМЕРЫ (см. стр. 33)



Отдельно стоящая ванна с внешней обшивкой.



СХЕМА ПОТОКА (см. стр. 34)

① Ручной душ

② Выход



ОЧИСТКА (см. стр. 38)



ТЕХНИЧЕСКОЕ ОБСЛУЖИВАНИЕ (см. стр. 36)

/ Защита обратного тока должна регулярно проверяться (минимум один раз в год) по стандарту DIN EN 1717 или в соответствии с национальными или региональными нормативами



ЭКСПЛУАТАЦИЯ (см. стр. 35)



КОМПЛЕКТ (см. стр. 37)

СПЕЦИАЛЬНЫЕ ПРИНАДЛЕЖНОСТИ (не включено в объем поставки!)



/ Удлинение 60 mm #97686000 (см. стр. 37)



/ Удлинение 60 mm #10981000 (см. стр. 37)



/ Удлинение 20 mm #10983000 (см. стр. 37)



/ Монтажный ключ #58085000 (см. стр. 32+37)

△ BIZTONSÁGI UTASÍTÁSOK

- △ A szerelésnél a zúzódások és vágási sérülések elkerülése érdekében kesztyűt kell viselni.
- △ A terméket csak fürdéshez, mosakodáshoz, és egészségügyi tisztálkodáshoz szabad használni.
- △ Gyermekek, valamint testileg, szellemileg fogyatékos és/vagy érzékelésben korlátozott személyek nem használhatják felügyelet nélkül a terméket. Alkohol és kábítószer befolyása alatt álló személyek nem használhatják a terméket.
- △ Kerülni kell a zuhansugár érintkezését érzékeny testrészekkel (pl. szemek). Be kell tartani a megfelelő távolságot a zuhanyfej és a test között.
- △ A terméket nem szabad kapaszkodónak használni. Ehhez külön kapaszkodót kell felszerelni.
- △ A hidegvíz- és a melegvíz-csatlakozások közötti nagy nyomáskülönbséget kicell egyenlíteni!

SZERELÉSI UTASÍTÁSOK

- / A szerelés előtt ellenőrizni kell, hogy a terméknek nincs-e szállítási sérülése. Beépítés után a szállítási- vagy felületi sérüléseket nem ismerik el.
- / A vezetékeket és a csaptelepet az érvényes szabványoknak megfelelően kell felszerelni, öblíteni és ellenőrizni
- / Az egyes országokban érvényes installációs irányelveket be kell tartani.
- / A kézi zuhanyhoz csomagolt szűrőtömítést be kell szerelni a vízhálózatból származó szennyeződések kiküszöbölésére. A beáramló szennyeződések akadályozhatják és/vagy teljesen tönkre is tehetik a zuhany funkciót. Az ezekből adódó károkat a Hansgrohe nem felel.

MŰSZAKI ADATOK

Üzemi nyomás:	max. 1 MPa
Ajánlott üzemi nyomás:	0,1 - 0,5 MPa
Nyomáspróba:	1,6 MPa
	(1 MPa = 10 bar = 147 PSI)
Forróvíz hőmérséklet:	max. 70°C
Forróvíz javasolt hőmérséklete:	65°C
Termikus fertőtlenítés:	max. 70°C/4 perc

- / Visszafolyás gátlóval
- / A terméket kizárólag ivóvízhez tervezték!

SZIMBÓLUMOK LEÍRÁSA





-  Ne használjon ecetsavtartalmú szilikon!
-  M É R E T E T (lásd a oldalon 33)
-  Szabadon álló kád külső burkolattal.
-  Á T F O L Y Á S I D I A G R A M M (lásd a oldalon 34)
 - ① Kézi zuhany
 - ② Kifolyó csatlakozó
-  T I S Z T Í T Á S (lásd a oldalon 38)
-  K A R B A N T A R T Á S (lásd a oldalon 36)
 - / A visszafolyásgátlók működése a DIN EN 1717 szabványnak megfelelően, a nemzeti vagy területi rendelkezésekkel összhangban, évente egyszer ellenőrizendő!

-  H A S Z N Á L A T (lásd a oldalon 35)

-  T A R T O Z É K O K (lásd a oldalon 37)

EGYÉB TARTOZÉK

(a szállítási egység nem tartalmazza)

-  / Hosszabbítás 60 mm #97686000 (lásd a oldalon 37)
-  / Hosszabbítás 60 mm #10981000 (lásd a oldalon 37)
-  / Hosszabbítás 20 mm #10983000 (lásd a oldalon 37)
-  / Szerelőkulcs #58085000 (lásd a oldalon 32+37)



SZERELÉS (lásd a oldalon 31)

△ TURVALLISUUSOHJEET

- △ Asennuksessa on käytettävä käsiineitä puristumien ja viiltojen aiheuttamien tapaturmien estämiseksi.
- △ Tuotetta saa käyttää ainoastaan kylpy-, hygienia- ja puhdistustarkoituksiin.
- △ Lapset ja ruumiillisesti, henkisesti ja/tai aistillisesti rajoittuneet aikuiset eivät saa käyttää suihkujärjestelmää ilman valvontaa. Alkoholin tai huumeiden vaikutuksessa olevat henkilöt eivät saa käyttää suihkujärjestelmää.
- △ Suihkuveden kontaktia herkkien ruumiinosien (esim. silmien) kanssa on vältettävä. Suihkun ja vartalon välissä on oltava riittävä väli.
- △ Tuotetta ei saa käyttää kädensijana. On asennettava erillinen kädensija.
- △ Suuret paine-erot kylmä- ja kuumavesiliitännöiden välillä on tasattava.

ASENNUSOHJEET

- / Ennen asennusta on tarkastettava tuotteen mahdolliset kuljetusvahingot. Asennuksen jälkeen kuljetus- ja pintavaurioita ei hyväksytä.
- / Putket ja hana on asennettava, huuhdeltava ja tarkastettava voimassa olevien standardien mukaisesti.
- / Jokaisessa maassa on noudatettava siellä päteviä asennusohjeita.
- / Käsिसuihkun mukana toimitettu sihtitiiviste on asennettava paikalleen, jotta lian huuhtoutuminen vesijohtoverkostosta käsisisuihkuun estyy. Huuhtoutuvat likahiukkaset voivat häiritä suihkun toimintaa tai vahingoittaa toimintaosia, Hansgrohe ei vastaa tästä aiheutuneista vahingoista.

TEKNISET TIEDOT

Käyttöpaine:	maks. 1 MPa
Suosittelut käyttöpaine:	0,1 - 0,5 MPa
Koestuspaine:	1,6 MPa
	(1 MPa = 10 bar = 147 PSI)
Kuuman veden lämpötila:	maks. 70°C
Kuuman veden suosituslämpötila:	65°C
Lämpödesinfektio:	maks. 70°C / 4 min

- / Estää itsestään paluuvirtauksen
- / Tuote on suunniteltu käytettäväksi ainoastaan juomaveden kanssa!

MERKIN KUVAUS



Älä käytä etikkahappopitoista silikonial



MITAT (katso sivu 33)



Vapaasti seisova kylpyamme ulkopuolisella verhouksella.



VIRTAUSDIAGRAMMI (katso sivu 34)

- ① Käsisisuihku
- ② Juoksuputki



PUHDISTUS (katso sivu 38)



HUOLTO (katso sivu 36)

- / Vastaventtiilien toiminta on tarkastettava säännöllisesti paikallisten ja kansallisten määräysten mukaisesti (DIN EN 1717, vähintään kerran vuodessa).



KÄYTTÖ (katso sivu 35)



VARAOSAT (katso sivu 37)

ERITYISVARUSTE (ei kuulu toimitukseen)



/ Pidennys 60 mm #97686000 (katso sivu 37)



/ Pidennys 60 mm #10981000 (katso sivu 37)



/ Pidennys 20 mm #10983000 (katso sivu 37)



/ Asennusavain #58085000 (katso sivu 32+37)



ASENNUS (katso sivu 31)

△ SÄKERHETSANVISNINGAR

- △ Handskar ska bäras under monteringsarbetet så att man kan undvika kläm- och skärskadorna werden.
- △ Produkten får bara användas till kroppshygien med bad och dusch.
- △ Barn samt vuxna med fysiska, psykiska eller sensoriska funktionshinder får inte använda produkten ensamma. Personer som är påverkade av alkohol- eller droger får inte använda produkten.
- △ Undvik att riktiga duschstrålarna mot känsliga kroppsdelar (t. ex. ögonen). Det måste finnas ett tillräckligt stort avstånd mellan duschen och kroppen.
- △ Produkten får inte användas som handtag. Ett separat handtag måste monteras.
- △ Stora tryckskillnader mellan anslutningarna för varmt och kallt vatten måste utjämnas.

MONTERINGSANVISNINGAR

- / Det måste undersökas om produkten har transportskador innan den monteras. Efter monteringen accepteras inga transport- eller ytskiktsskador.
- / Ledningarna och blandaren måste monteras, spolas igenom och kontrolleras enligt de gällande normerna.
- / De installationsriktlinjer som gäller i länderna ska följas.
- / Silpackningen som följer med duschen måste monteras för att undvika att smuts från ledningsnätet tränger in. Smuts som spolas in kan påverka funktionerna och/eller leda till skador på funktionsdelar i duschen. Hansgrohe fransäger sig allt ansvar för skador som kan härledas till detta.

TEKNISKA DATA

Driftstryck:	max. 1 MPa
Rek. driftstryck:	0,1 - 0,5 MPa
Tryck vid provtryckning:	1,6 MPa
	(1 MPa = 10 bar = 147 PSI)
Varmvattentemperatur:	max. 70°C
Rek. varmvattentemp.:	65°C
Termisk desinfektion:	max. 70°C / 4 min

- / Självspärr mot återflöde
- / Produkten är enbart avsedd för dricksvatten!

SYMBOLFÖRKLARING

-  Använd inte silikon som innehåller ättiksyra!
-  MÅTTEN (se sidan 33)
-  Fristående badkar med front.
-  FLÖDESCHEMA (se sidan 34)
 - ① Handdusch
 - ② Utdragbar blandare
-  RENGÖRING (se sidan 38)
-  SKÖTSEL (se sidan 36)
 - / Backventilens funktion måste kontrolleras regelbundet enligt nationella eller regionala bestämmelser i enlighet med DIN EN 1717 (minst en gång per år).
-  HANTERING (se sidan 35)
-  RESERVDELAR (se sidan 37)
- SPECIALTILLBEHÖR (medföljer ej leveransen)
 -  / Förlängning 60 mm #97686000 (se sidan 37)
 -  / Förlängning 60 mm #10981000 (se sidan 37)
 -  / Förlängning 20 mm #10983000 (se sidan 37)
 -  / Monteringsnyckel #58085000 (se sidan 32+37)



MONTERING (se sidan 31)

SAUGUMO TECHNIKOS NURODYMAI

- ⚠ Apsaugai nuo užspaudimo ir įsijovimo montavimo metu mūvėkite pirštines.
- ⚠ Gaminys turi būti naudojamas tik maudymuisi, kūno higienai ir švarai palaikyti.
- ⚠ Gaminį draudžiama naudoti vaikams, taip pat suaugusiems su fizine, dvasine negale ir (arba) sensorikos sutrikimais. Gaminį taip pat draudžiama naudoti asmenims, apsvaigusiems nuo alkoholio arba narkotikų.
- ⚠ Būtina vengti dušo vandens srovės kontakto su jautriomis kūno vietomis (pvz., akimis). Todėl būtina laikytis tinkamo atstumo nuo dušo.
- ⚠ Gaminys neturi būti naudojamas kaip rankena. Rankena montuojama atskirai.
- ⚠ Turi būti išlyginti šalto ir karšto slėgio nelygumai.

MONTAVIMO INSTRUKCIJA

- / Prieš montuojant būtina patikrinti, ar gaminys nebuvo pažeistas transportavimo metu. Sumontavus pretenzijos dėl transportavimo ir paviršiaus pažeidimų nepriimamos.
- / Vamzdžiai ir sujungimai turi būti montuojami, plaunami ir tikrinami pagal galiojančias normas.
- / Laikykites atitinkamoje šalyje galiojančių direktyvų dėl įrengimo.
- / Tinklelis, kuris yra rankų dušas pakuotėje, privalo būti įstatytas, kad būtų apsaugota nuo išorės nešvarumų. Nešvarumai gali pakenkti rankų dušas funkcionalumui ir (arba) sugadinti rankų dušas funkcines dalis. Tokiu atveju "Hansgrohe" atsakomybės neprišima.

TECHNINIAI DUOMENYS

Darbinis slėgis: ne daugiau kaip 1 MPa
 Rekomenduojamas slėgis: 0,1 - 0,5 MPa
 Bandomasis slėgis: 1,6 MPa
 (1 MPa = 10 barų = 147 PSI)

Karšto vandens temperatūra: ne daugiau kaip 70°C
 Rekomenduojama karšto vandens temperatūra: 65°C
 Terminis dezinfekavimas: ne daugiau kaip 70°C / 4 min

- / Su atbuliniu vožtuvu
- / Produktas skirtas tik geriamajam vandeniui!

SIMBOLIO APRAŠYMAS



Nenaudokite silikono, kurio sudėtyje yra acto rūgšties!



IŠMATAVIMAI (žr. psl. 33)



Atskira vonia su dangčiu.



PRALAIIDUMO DIAGRAMA (žr. psl. 34)

- ① Rankų dušas
- ② čiaupas



VALYMAS (žr. psl. 38)



TECHNINIS APTARNAVIMAS (žr. psl. 36)

/ Atbulinio vožtuvo apsauga privalo būti tikrinama reguliariai (mažiausiai kartą per metus) pagal DIN EN1717 arba pagal galiojančias nacionalines arba regionines normas.



EKSPLOATACIJA (žr. psl. 35)



ATSARGINĖS DALYS (žr. psl. 37)

SPECIALŪS PRIEDAI (nėra pridedama)



/ Ilgiklis 60 mm #97686000 (žr. psl. 37)



/ Ilgiklis 60 mm #10981000 (žr. psl. 37)



/ Ilgiklis 20 mm #10983000 (žr. psl. 37)



/ Montavimo raktas #58085000 (žr. psl. 32+37)



MONTAVIMAS (žr. psl. 31)

△ SIGURNOSNE UPUTE

- △ Prilikom montaže se radi sprječavanja prignječenja i posjekotina moraju nositi rukavice.
- △ Proizvod se smije primjenjivati samo za kupanje, tuširanje i osobnu higijenu.
- △ Djeca, kao i tjelesno, mentalno i/ili senzorno hendikepirane odrasle osobe ne smiju se koristiti proizvodom bez nadzora. Osobe koje su pod utjecajem alkohola ili droga ne smiju se koristiti proizvodom.
- △ Mora se izbjegavati kontakt mlaza iz tuša s osjetljivim dijelovima tijela (npr. očima). Tijelo korisnika mora biti dovoljno udaljeno od tuša.
- △ Proizvod ne smije služiti za pridržavanje. U tu se svrhu mora postaviti zaseban rukohvat.
- △ Velika razlika u pritisku između vruće i hladne vode mora biti izbalansirana.

UPUTE ZA MONTAŽU

- / Prije montaže mora se provjeriti je li proizvod oštećen prilikom transporta. Nakon ugradnje se ne priznaju nikakve reklamacije koje se odnose na površinska i transportna oštećenja.
- / Cijevi i armatura moraju biti postavljeni, isprani i testirani prema važećim normama.
- / Obvezno se moraju uvažiti propisi o instalacijama koji vrijede u dotičnoj zemlji.
- / Filter potrebno je ugraditi kako bi se regulirao protok vode i smanjio dotok prljavštine. Za eventualna oštećenja uzrokovana prljavštinom proizvođač Hansgrohe nije odgovoran.

TEHNIČKI PODATCI

- | | |
|-------------------------------------|----------------------------|
| Najveći dopušteni tlak: | tlak 1 MPa |
| Preporučeni tlak: | 0,1 - 0,5 MPa |
| Probni tlak: | 1,6 MPa |
| | (1 MPa = 10 bar = 147 PSI) |
| Temperatura vruće vode: | tlak 70°C |
| Preporučena temperatura vruće vode: | 65°C |
| Termička dezinfekcija: | tlak 70°C / 4 min |
- / Funkcije samo-čišćenja
 - / Proizvod je koncipiran isključivo za pitku vodu!

OPIS SIMBOLA

-  Nemojte koristiti silikon koji sadrži octenu kiselinu!
-  MJERE (pogledaj stranicu 33)
-  Kada je slobodna sa vanjskim oblogom.
-  DIJAGRAM PROTOKA (pogledaj stranicu 34)
 - ① Ručni tuš
 - ② Slavina
-  ČIŠĆENJE (pogledaj stranicu 38)
-  ODRŽAVANJE (pogledaj stranicu 36)
 - / Ispravnost nepovratnog ventila mora se redovito provjeravati prema standardu DIN EN 1717 i u skladu sa važećim propisima (najmanje jednom godišnje).
-  UPOTREBA (pogledaj stranicu 35)
-  REZERVNI DJELOVI (pogledaj stranicu 37)
- POSEBNI PRIBOR (Nije sadržano u isporuci!)
 -  / Produljenje 60 mm #97686000 (pogledaj stranicu 37)
 -  / Produljenje 60 mm #10981000 (pogledaj stranicu 37)
 -  / Produljenje 20 mm #10983000 (pogledaj stranicu 37)
 -  / ključ za montažu #58085000 (pogledaj stranicu 32+37)



SASTAVLJANJE (pogledaj stranicu 31)

⚠ GÜVENLİK UYARILARI

- ⚠ Montaj esnasında ezilme ve kesilme gibi yaralanmaları önlemek için eldiven kullanılmalıdır.
- ⚠ Ürün yalnızca banyo, hijyen ve beden temizliği amaçları doğrultusunda kullanılabilir.
- ⚠ Bedensel, ruhsal ve/veya sensörük engelli çocuk ve yetişkinler gözetimsiz olarak duş sistemini kullanmamalıdır. Alkol veya uyuşturucu etkisinde olanlar duş sistemini kullanmamalıdır.
- ⚠ Püskürtme başlıklarının hassas organlara teması (örn. gözler) önlenmelidir. Püskürtücü ile beden arasında yeterli mesafe bırakılmalıdır.
- ⚠ Ürün tutma kolu olarak kullanılmamalıdır. Ayrı bir tutma kolu monte edilmelidir.
- ⚠ Sıcak ve soğuk su bağlantıları arasında büyük basınç farklılıkları varsa, bu basınç farklılıklarının dengelenmesi gerekir.

MONTAJ AÇIKLAMALARI

- / Montaj işleminden önce ürün nakliye hasarları yönünden kontrol edilmelidir. Montaj işleminden sonra nakliye veya yüzey hasarları için sorumluluk üstlenilmemektedir.
- / Boruların ve armatürün montajı, yıkanması ve kontrolü geçerli normlara göre yapılmalıdır.
- / Ülkelerde geçerli kurulum yönetmeliklerine riayet edilmelidir.
- / El duşu kafasına eklenmiş olan süzgeç contası, boru şebekesinden sızan kirlerin önüne geçmek için, yerine monte edilmelidir. İçeri sızan bu kirler duşun fonksiyonunu sekteleyebilir ve/veya duşun fonksiyon parçaları üzerinde hasarlara sebep olabilir, bu yüzden meydana gelen hasarlardan Hansgrohe sorumlu tutulamaz.

TEKNİK BİLGİLER

İşletme basıncı:	azami 1 MPa
Tavsiye edilen işletme basıncı:	0,1 - 0,5 MPa
Kontrol basıncı:	1,6 MPa
	(1 MPa = 10 bar = 147 PSI)
Sıcak su sıcaklığı:	azami 70°C
Tavsiye edilen su ısısı:	65°C
Termik dezenfeksiyon:	azami 70°C/4 dak

- / Geri emme önleyici
- / Ürün sadece şebeke suyu için tasarlanmıştır

SİMGE AÇIKLAMASI

-  Asetik asit içeren silikon kullanmayın!
-  ÖLÇÜLERİ (bakınız sayfa 33)
-  Dış kaplamalı boшта duran kütet.
-  AKIŞ DİYAGRAMI (bakınız sayfa 34)
- ① El duşu
- ② Menfez
-  TEMİZLEME (bakınız sayfa 38)
-  BAKIM (bakınız sayfa 36)
- / DIN EN 1717 ve ulusal standartlar doğrultusunda Çek valfler düzenli olarak kontrol edilmelidir. (en az yılda bir kez)
-  KULLANIMI (bakınız sayfa 35)
-  YEDEK PARÇALAR (bakınız sayfa 37)
- ÖZEL AKSESUARLAR
(Teslimat kapsamına dahil değildir)
-  / Uzatma 60 mm #97686000 (bakınız sayfa 37)
-  / Uzatma 60 mm #10981000 (bakınız sayfa 37)
-  / Uzatma 20 mm #10983000 (bakınız sayfa 37)
-  / Montaj anahtarı #58085000 (bakınız sayfa 32+37)



MONTAJI (bakınız sayfa 31)

△ INSTRUCȚIUNI DE SIGURANȚĂ

- △ La montare utilizați mănuși pentru evitarea contuziunilor și tăierii mâinilor.
- △ Produsul poate fi utilizat doar pentru spălarea, menținerea igienei și curățarea corpului.
- △ Copiii și adulții cu dizabilități corporale, mintale și senzoriale nu pot utiliza sistemul de duș nesupravegheați. De asemenea este interzisă utilizarea sistemului de duș de către persoane, care se află sub influența alcoolului sau a drogurilor.
- △ Evitați contactul jetului de apă cu părțile de corp sensibile (de ex. ochii). Țineți dușul la o distanță corespunzătoare de corp.
- △ Nu este permisă utilizarea produsului pe post de mâner. este nevoie de montarea unui mâner corespunzător.
- △ Diferențele de presiune mari între alimentarea cu apă rece și apă caldă trebuie echilibrate.

INSTRUCȚIUNI DE MONTARE

- / Înainte de instalare verificați, dacă produsul prezintă deteriorări de transport. După instalare garanția nu acoperă deteriorările de transport și cele de suprafață.
- / Conductele și bateriile trebuie montate, spălate și verificate conform normelor în vigoare.
- / Respectați reglementările referitoare la instalare valabile în țara respectivă.
- / Montați garnitura de filtru livrată împreună cu capătul de duș de mână pentru evitarea pătrunderii impurităților din rețeaua de alimentare. Impuritățile pătrunse pot influența funcționarea aparatului și/sau provoca deteriorarea capătului de duș. Garanția nu acoperă aceste daune.

DATE TEHNICE

Presiune de funcționare:	max. 1 MPa
Presiune de funcționare recomandată:	0,1 - 0,5 MPa
Presiune de verificare:	1,6 MPa
	(1 MPa = 10 bar = 147 PSI)
Temperatura apei calde:	max. 70°C
Temperatura recomandată a apei calde:	65°C
Dezinfecție termică:	max. 70°C / 4 min

- / Asigurat contra scurgere înapoi
- / Produsul este destinat exclusiv pentru apă potabilă.

DESCRIEREA SIMBOLURILOR

-  Nu utilizați silicon cu conținut de acid acetic!
-  DIMENSIUNI (vezi pag. 33)
-  Cadă de baie cu suport și panou.
-  DIAGRAMA DE DEBIT (vezi pag. 34)
 - ① Duș de mână
 - ② Pipă
-  CURĂȚARE (vezi pag. 38)
-  ÎNTREȚINERE (vezi pag. 36)
 - / Supapele antiretur trebuie verificate regulat conform DIN EN 1717 și standardele naționale sau regionale (cel puțin o dată pe an).
-  UTILIZARE (vezi pag. 35)
-  PIESE DE SCHIMB (vezi pag. 37)
- ACCESORII OPȚIONALE (nu este inclus în setul livrat)
 -  / Prelungitor 60 mm #97686000 (vezi pag. 37)
 -  / Prelungitor 60 mm #10981000 (vezi pag. 37)
 -  / Prelungitor 20 mm #10983000 (vezi pag. 37)
 -  / Cheie pentru montare #58085000 (vezi pag. 32+37)



MONTARE (vezi pag. 31)

Δ ΥΠΟΔΕΙΞΕΙΣ ΑΣΦΑΛΕΙΑΣ

- Δ Για να αποφύγετε τραυματισμούς κατά τη συναρμολόγηση πρέπει να φοράτε γάντια.
- Δ Το προϊόν επιτρέπεται να χρησιμοποιείται μόνο σαν μέσο λουτρού, υγιεινής και καθαρισμού του σώματος.
- Δ Παιδιά ή ενήλικες με μειωμένες σωματικές, διανοητικές και/ή αισθητήριες ανεπάρκειες δεν επιτρέπεται να χρησιμοποιούν το προϊόν χωρίς επιτήρηση. Άτομα υπό την επήρεια οινοπνεύματος ή ναρκωτικών δεν επιτρέπεται να χρησιμοποιούν σε καμία περίπτωση το προϊόν.
- Δ Η επαφή δέσμης νερού του ντους με ευαίσθητες περιοχές του σώματος (π.χ. μάτια) πρέπει να αποφεύγεται. Διατηρείτε επαρκή απόσταση ανάμεσα στο ντους και το σώμα.
- Δ Το προϊόν δεν επιτρέπεται να χρησιμοποιείται σαν λαβή στήριξης. Για τον σκοπό αυτό πρέπει να τοποθετηθεί ξεχωριστή λαβή στήριξης.
- Δ Οι διαφορές της πίεσης μεταξύ της σύνδεσης κρύου και ζεστού νερού θα πρέπει να αντισταθμίζονται.

Ο Δ Η Γ Ι Ε Σ Σ Υ Ν Α Ρ Μ Ο Λ Ο Γ Η Σ Η Σ

- / Πριν τη συναρμολόγηση πρέπει να εξεταστεί το προϊόν για ζημιές μεταφοράς. Μετά την εγκατάσταση δεν αναγνωρίζονται ζημιές από τη μεταφορά ή επιφανειακές ζημιές.
- / Οι σωλήνες και η μπαταρία πρέπει να τοποθετηθούν σύμφωνα με τα ισχύοντα πρότυπα, να τεθούν υπό πίεση και να δοκιμαστούν.
- / Θα πρέπει να τηρούνται οι οδηγίες εγκατάστασης που ισχύουν σε κάθε κράτος.
- / Πρέπει να εγκατασταθεί το παρέμβυσμα φίλτρου που συνοδεύει τον καταιονιστήρα κατά τέτοιο τρόπο, ώστε να αποφεύγονται ρύποι που προέρχονται από το δίκτυο ύδρευσης. Οι ρύποι από το δίκτυο ύδρευσης μπορούν να επηρεάσουν αρνητικά και/ή να προξενήσουν ζημιά στα λειτουργικά τμήματα του καταιονιστήρα (ντους). Τέτοιου είδους ζημιές δεν καλύπτονται από την εγγύηση Hansgrohe.

Τ Ε Χ Ν Ι Κ Α Χ Α Ρ Α Κ Τ Η Ρ Ι Σ Τ Ι Κ Α

Λειτουργία πίεσης:	έως 1 MPa
Συνιστώμενη λειτουργία πίεσης:	0,1 - 0,5 MPa
Πίεση ελέγχου:	1,6 MPa
	(1 MPa = 10 bar = 147 PSI)
Θερμοκρασία ζεστού νερού:	έως 70°C
Συνιστώμενη θερμοκρασία ζεστού νερού:	65°C
Θερμική απολύμανση:	έως 70°C / 4 min

- / Περιλαμβάνει βαλβίδα αντεπιστροφής.
- / Το προϊόν έχει σχεδιαστεί αποκλειστικά για πόσιμο νερό!

Π Ε Ρ Ι Γ Ρ Α Φ Η Σ Υ Μ Β Ο Λ Ω Ν



Μην χρησιμοποιείτε σιλικόνη που περιέχει οξικό οξύ!



Δ Ι Α Σ Τ Α Σ Ε Ι Σ (βλ. Σελίδα 33)



Μπαγιέρα ελεύθερης τοποθέτησης με εξωτερική επένδυση.



Δ Ι Α Γ Ρ Α Μ Μ Α Ρ Ο Η Σ (βλ. Σελίδα 34)

Ⓛ Καταιονιστήρας χειρός

Ⓜ Αποχέτευση



Κ Α Θ Α Ρ Ι Σ Μ Ο Σ (βλ. Σελίδα 38)



Σ Υ Ν Τ Η Ρ Η Σ Η (βλ. Σελίδα 36)

/ Οι βαλβίδες αντεπιστροφής πρέπει να ελέγχονται τακτικά ως προς τη λειτουργία τους, σύμφωνα με το πρότυπο DIN EN 1717, σε σχέση με τους ισχύοντες εθνικούς ή τοπικούς κανόνες (το ελάχιστο μια φορά το χρόνο).



Χ Ε Ι Ρ Ι Σ Μ Ο Σ (βλ. Σελίδα 35)



Α Ν Τ Α Λ Λ Α Κ Τ Ι Κ Α (βλ. Σελίδα 37)

Ε Ι Δ Ι Κ Α Α Ξ Ε Σ Ο Υ Ρ Α Ρ (δεν περιλαμβάνεται στον παραδοτέο εξοπλισμό)



/ Σωλήνας επιμήκυνσης 60 mm #97686000 (βλ. Σελίδα 37)



/ Σωλήνας επιμήκυνσης 60 mm #10981000 (βλ. Σελίδα 37)



/ Σωλήνας επιμήκυνσης 20 mm #10983000 (βλ. Σελίδα 37)



/ Κλειδί συναρμολόγησης #58085000 (βλ. Σελίδα 32+37)



Σ Υ Ν Α Ρ Μ Ο Λ Ο Γ Η Σ Η (βλ. Σελίδα 31)

△ VARNOSTNA OPOZORILA

- △ Pri montaži je treba nositi rokavice, da se preprečijo poškodbe zaradi zmečkanja ali urezov.
- △ Ta izdelek se sme uporabljati le z namenom umivanja, vzdrževanja higiene in telesne nege.
- △ Otroci kot tudi odrasle osebe z omejenimi telesnimi, duševnimi in/ali senzoričnimi sposobnostmi ne smejo nenadzorovano uporabljati tega izdelka. Osebe, ki so pod vplivom alkohola ali drog, tega izdelka ne smejo uporabljati.
- △ Izgibati se je treba stiku prhalnega curka z občutljivimi deli telesa (npr. očmi). Med telesom in prho mora biti vedno zadosten razmik.
- △ Proizvoda ne smete uporabljati kot držalnega ročaja. V ta namen je treba montirati poseben ročaj.
- △ Velike razlike v tlaku med priključkom za mrzlo in priključkom za toplo vodo je potrebno izravnati.

NAVODILA ZA MONTAŽO













- / Pred montažo je treba izdelek preveriti glede morebitnih transportnih poškodb. Po vgradnji transportne ali površinske poškodbe ne bodo več priznane.
- / Cevi in armaturo je treba montirati, izprati in preveriti po veljavnih standardih.
- / Upoštevati je treba pravilnike o inštalacijah, ki veljajo v posamezni državi.
- / Filter, ki je priložen ročni prhi, je potrebno vgraditi, da prho zaščitimo pred umazanijo iz vodovodne napeljave. Umazanija lahko okvari ali poškoduje dele ročne prhe. Za tako nastalo škodo Hansgrohe ne odgovarja.

TEHNIČNI PODATKI

Delovni tlak:	maks. 1 MPa
Priporočeni delovni tlak:	0,1 - 0,5 MPa
Preskusni tlak:	1,6 MPa
	(1 MPa = 10 bar = 147 PSI)
Temperatura tople vode:	maks. 70°C
Priporočena temperatura tople vode:	65°C
Termična dezinfekcija:	maks. 70°C/4 min

- / Zaščita proti povratnemu toku
- / Proizvod je zasnovan izključno za sanitarno vodo!

OPIS SIMBOLA

-  Ne smete uporabiti silikona, ki vsebuje ocatno kislino!
-  MERE (glejte stran 33)
-  Kopalna kad prostostoječa z zunanjo oblogo.
-  DIAGRAM PRETOKA (glejte stran 34)
 - ① Ročna prha
 - ② Izliv
-  ČIŠČENJE (glejte stran 38)
-  VZDRŽEVANJE (glejte stran 36)
 - / Delovanje protipovratnega ventila je potrebno v skladu z DIN EN 1717 in skladno z državnimi in regionalnimi določili redno testirati (najmanj enkrat letno).
-  UPRAVLJANJE (glejte stran 35)
-  REZERVNI DELI (glejte stran 37)
- POSEBEN PRIBOR (Ni vključeno)
 -  / Podaljšek 60 mm #97686000 (glejte stran 37)
 -  / Podaljšek 60 mm #10981000 (glejte stran 37)
 -  / Podaljšek 20 mm #10983000 (glejte stran 37)
 -  / Montažni ključ #58085000 (glejte stran 32+37)



MONTAŽA (glejte stran 31)

△ OHUTUSJUHISED

- △ Kandke paigaldamisel muljumis- ja löikevigastuste vältimiseks kindaid.
- △ Toodet tohib kasutada ainult pesemis-, hügieeni- ja kehapuhastamisesmärkidel.
- △ Lapsed, samuti kehaliste, vaimsete või tajupiirangutega täiskasvanud ei tohi dušisüsteemi järelvalveta kasutada. Alkoholi või narkootikumide mõju all olevad isikud ei tohi dušisüsteemi kasutada.
- △ Duši veejoad ei tohi kokku puutuda tundlike kehaosadega (nt silmad). Jätke duši ja keha vahele piisav vahe.
- △ Toodet ei tohi kasutada käepidemena. Paigaldage eraldi käepide.
- △ Kui külma ja kuuma vee ühenduste surve on väga erinev, tuleb need tasakaalustada.

PAIGALDAMISJUHISED

- / Enne paigaldamist tuleb toodet kontrollida transpordikahjustuste osas. Pärast paigaldamist ei tunnustata enam transpordi- või pinnakahjustuste kaebuseid.
- / Voolikute ja segisti paigaldamisel, loputamisel ja kontrollimisel tuleb lähtuda kehtivatest normatiividest.
- / Vastavas riigis kehtivaid paigalduseeskirju tuleb järgida.
- / Kaitsmaks dušši torust tuleva mustuse eest, on vaja paigaldada dušiga kaasasolev mustusesõel. Sissetulev mustus võib funktsioneerimist kahjustada ja/või rikkuda duši detaile. Sellest tulenevate kahjude eest Hansgrohe ei vastuta.

TEHNILISED ANDMED

Töörõhk	maks. 1 MPa
Soovitav töörõhk:	0,1 - 0,5 MPa
Kontrollsurve:	1,6 MPa
	(1 MPa = 10 baari = 147 PSI)
Kuuma vee temperatuur:	maks. 70°C
Soovitav kuuma vee temperatuur:	65°C
Terminline desinfitatsioon:	maks. 70°C / 4 min

- / Tagasivooluklapp
- / Toode on ette nähtud eranditult joogivee jaoks!

SÜMBOLITE KIRJELDUS



Ärge kasutage äädikhapet sisaldavat silikoonil!



MÕÕTUDE (vt lk 33)



eraldi asetsev välivoodriga vann.



LÄBIVOOLUDIAGRAMM (vt lk 34)

① Käsidušš

② jooksutoru



PUHASTAMINE (vt lk 38)



HOOLDUS (vt lk 36)

/ Tagasilöögiklappide toimimist tuleb kooskõlas riiklike ja regionaalsete määrustega regulaarselt kontrollida vastavalt standardile DIN EN 1717 (vähemalt kord aastas).



KASUTAMINE (vt lk 35)



VARUOSAD (vt lk 37)

SPETSIAALNE LISAVARUSTUS
(ei sisaldu komplektis)



/ Pikendus 60 mm #97686000 (vt lk 37)



/ Pikendus 60 mm #10981000 (vt lk 37)



/ Pikendus 20 mm #10983000 (vt lk 37)



/ Montaaživõti #58085000 (vt lk 32+37)



PAIGALDAMINE (vt lk 31)

△ DROŠĪBAS NORĀDES

- △ Montāžas laikā, lai izvairītos no saspiedumiem un iegriezumiem, nepieciešams nēsāt cimdus.
- △ Šo produktu drīkst izmantot tikai, lai mazgātos, higiēnai un ķermeņa tīrīšanai.
- △ Bērni, kā arī pieaugušie ar fiziskiem, garīgiem un/vai sensoriskiem ierobežojumiem nedrīkst lietot šo produktu bez uzraudzības. Personas, kas atrodas alkohola vai narkotisko vielu iespaidā, nedrīkst lietot šo dušas sistēmu.
- △ Nepieciešams izvairīties no dušas strūklas tieša kontakta ar jutīgām ķermeņa daļām (piem., acīm). Nepieciešams ievērot pietiekošu attālumu starp dušu un ķermeni.
- △ Šo produktu nedrīkst izmantot kā roku balstu. Nepieciešams uzmontēt atsevišķu roku balstu.
- △ Jāizlīdzina spiediena atšķirības starp aukstā un karstā ūdens pievadiem.

NORĀDĪJUMI MONTĀŽAI

- / Pirms montāžas nepieciešams pārbaudīt, vai produktam transportēšanas laikā nav radušies bojājumi. Pēc iebūvēšanas bojājumi, kas radušies transportēšanas laikā, vai virsmas bojājumi netiek atzīti.
- / Caurulvadi un armatūra ir jāuzstāda, jāizskalo un jāpārbauda saskaņā ar spēkā esošajiem standartiem.
- / Jāievēro attiecīgās valstīs spēkā esošās montāžas prasības.
- / Jāiemontē dušas komplektā esošais filtrs, lai novērstu neīrurumu iepļūšanu no ūdens vada. Ieskatoties neīrurumi var traucēt dušas funkciju un/vai arī izraisīt rokas dušas daļu bojājumus, par kuriem Hansgrohe nenes atbildību.

TEHNISKIE DATI

Darba spiediens:	maks. 1 MPa
Ieteicamais darba spiediens:	0,1 - 0,5 MPa
Pārbaudes spiediens:	1,6 MPa
	(1 MPa = 10 bar = 147 PSI)
Karstā ūdens temperatūra:	maks. 70°C
Ieteicamā karstā ūdens temperatūra:	65°C
Termiskā dezinfekcija :	maks. 70°C / 4 min

- / Drošības vārsts
- / Izstrādājums ir paredzēts tikai dzeramajam ūdenim!





SIMBOLU NOZĪME

-  Neizmantojiet silikonu, kas satur etiķskābi!
-  IZMĒRUS (skat. lpp. 33)
-  Brīvi stāvoša vanna ar paneli.
-  CAURPLŪDES DIAGRAMMA (skat. lpp. 34)
 - ① Rokas duša
 - ② Snipis
-  TĪRĪŠANA (skat. lpp. 38)
-  APKOPE (skat. lpp. 36)
 - / Regulāri jāpārbauda pretvārsta funkcija saskaņā ar DIN EN 1717 saistībā ar nacionālajiem vai vietējiem noteikumiem (vismaz vienreiz gadā).

-  LIETOŠANA (skat. lpp. 35)

-  REZERVES DAĻAS (skat. lpp. 37)

SPECIĀLI AKSESUĀRI (komplektā netiek piegādāti)

-  / Pagarinājums 60 mm #97686000 (skat. lpp. 37)
-  / Pagarinājums 60 mm #10981000 (skat. lpp. 37)
-  / Pagarinājums 20 mm #10983000 (skat. lpp. 37)
-  / Montāžas atslēga #58085000 (skat. lpp. 32+37)



MONTĀŽA (skat. lpp. 31)

△ SIGURNOSNE NAPOMENE

- △ Prilikom montaže se radi sprečavanja prignječenja i posekotina moraju nositi rukavice.
- △ Proizvod sme da se koristi samo za kupanje, tuširanje i ličnu higijenu.
- △ Deca, kao i telesno, mentalno i/ili senzorno hendikepirane odrasle osobe ne smeju da koriste proizvod bez nadzora. Osobe koje su pod uticajem alkohola ili droga ne smeju da koriste proizvod.
- △ Mora se izbegavati kontakt mlaza iz tuša sa osjetljivim delovima tela (npr. očima). Telo korisnika mora biti na dovoljnom odstojanju od tuša.
- △ Proizvod se ne sme koristiti za kao ručka za pridržavanje. U tu svrhu se mora postaviti zaseban rukohvat.
- △ Velika razlika u pritisku između vruće i hladne vode mora biti izbalansirana.

INSTRUKCIJE ZA MONTAŽU

- / Pre montaže se mora proveriti da li je proizvod oštećen pri transportu. Nakon ugradnje se ne priznaju nikakve reklamacije koje se odnose na površinska i transportna oštećenja.
- / Vodovi i armatura moraju biti postavljeni, isprani i testirani prema važećim normama.
- / Treba se pridržavati propisa koji u određenim zemljama važe za instalacije.
- / Obavezno ugradite mrežicu upakovanu s tušem, čime sprečavate ulazak prljavštine iz vodovoda. Prljavština može dovesti do delimičnog ili potpunog oštećenja delova tuša. Za eventualna oštećenja uzrokovana prljavštinom proizvođač Hansgrohe nije odgovoran.

TEHNIČKI PODACI

Radni pritisak:	maks. 1 MPa
Preporučeni radni pritisak:	0,1 - 0,5 MPa
Probni pritisak:	1,6 MPa
	(1 MPa = 10 bar = 147 PSI)
Temperatura vruće vode:	maks. 70°C
Preporučena temperatura vruće vode:	65°C
Termička dezinfekcija:	maks. 70°C / 4 min

- / Zaštita od povratnog toka
- / Proizvod je koncipiran isključivo za pijaću vodu!

OPIS SIMBOLA



Nemojte koristiti silikon koji sadrži sirčetnu kiselinu!



MERE (vidi stranu 33)



Samostojeća kada sa spoljašnjom oblogom.



DIJAGRAM PROTOKA (vidi stranu 34)

① Ručni tuš

② Slavina



ČIŠĆENJE (vidi stranu 38)



ODRŽAVANJE (vidi stranu 36)

/ Ispravno funkcionisanje nepovratnog ventila se mora redovno proveravati prema standardu DIN EN 1717 i u skladu s važećim nacionalnim ili regionalnim propisima (najmanje jednom godišnje).



UKOVANJE (vidi stranu 35)



REZERVNI DELOVI (vidi stranu 37)

POSEBAN PRIBOR

(Nije sadržano u isporuci)



/ Produžetak 60 mm #97686000 (vidi stranu 37)



/ Produžetak 60 mm #10981000 (vidi stranu 37)



/ Produžetak 20 mm #10983000 (vidi stranu 37)



/ ključ za montažu #58085000 (vidi stranu 32+37)



MONTAŽA (vidi stranu 31)

△ SIKKERHETSHENVISNINGER

- △ Bruk hansker under montasjen for å unngå klem- og kuttskader.
- △ Produktet skal kun brukes for bade-, hygiene- og kroppshygiene.
- △ Barn og voksne med fysiske og psykiske og/eller sensoriske handicap skal ikke bruke dusjsystemet uten oppsyn. Personer som er påvirket av alkohol eller narkotika skal ikke bruke dusjsystemet.
- △ Dusjstrålen skal ikke komme i kontakt med ømfintlige kroppsdeler (f.eks. øynene). Overhold en tilstrekkelig avstand mellom dusjen og kroppen.
- △ Produktet skal ikke brukes som holdegrep. Det skal monteres en separat holdegrep.
- △ Store trykkdifferanser mellom kaldt- og varmtvannstilkoblinger skal utlignes.

MONTAGEHENVISNINGER









- / Før montasjen skal produktet sjekkes for transportskader. Etter monteringen aksepteres ikke noen transport- eller overflateskader.
- / Ledningene og armaturen skal monteres, spyles og sjekkes iht. de gyldige normer.
- / Gjeldende retningslinjer for rørleggerarbeid i de enkelte land skal følges.
- / Silpakningen som er levert med dusjen skal bygges inn for å forhindre at smuss spyles inn fra ledningsnettet. Innspylt smuss kan påvirke funksjonen negativt og/eller kan medføre skader på hånddusjens funksjonsdeler. Hansgrohe påtar seg inget ansvar for skader som resulteres av dette.

TEKNISKE DATA

Driftstrykk	maks. 1 MPa
Anbefalt driftstrykk:	0,1 - 0,5 MPa
Prøvetrykk	1,6 MPa
	(1 MPa = 10 bar = 147 PSI)
Varmtvannstemperatur	maks. 70°C
Anbefalt temperatur for varmt vann	65°C
Termisk desinfisering:	maks. 70°C/4 min

- / Egensikker mot tilbakeflyt
- / Produktet er utelukkende designet for drikkevann!

SYMBOLBESKRIVELSE

-  Ikke bruk silikon som inneholder eddiksyre!
-  MÅL (se side 33)
-  Badekar med frittstående ytrepånel.
-  GJENNOMSTRØMNINGSDIAGRAM (se side 34)
 - ① Hånddusj
 - ② Utløp
-  RENGJØRING (se side 38)
-  VEDLIKEHOLD (se side 36)
 - / Funksjonen til returløpssperren skal iht. DIN EN 1717 og i samsvar med de nasjonale og lokale forskrifter sjekkes regelmessig (minst en gang i året).
-  BETJENING (se side 35)
-  SERVICEDELER (se side 37)
-  EKSTRATILBEHØR (ikke med i leveransen)
 - / Forlengelse 60 mm #97686000 (se side 37)
 - / Forlengelse 60 mm #10981000 (se side 37)
 - / Forlengelse 20 mm #10983000 (se side 37)
 - / Montasjenøkkel #58085000 (se side 32+37)



MONTASJE (se side 31)

⚠ УКАЗАНИЯ ЗА БЕЗОПАСНОСТ

- ⚠ При монтажа трябва да се носят ръкавици, за да се избегнат наранявания поради притискане или порязване.
- ⚠ Позволено е използването на продукта само за къпане, хигиена и цели на почистване на тялото.
- ⚠ Не е позволено деца, както и възрастни с физически, умствени и/или сензорни ограничения да използват продукта без надзор. Не е позволено използването на системата на продукта от лица, употребили алкохол или дрога.
- ⚠ Трябва да се избягва контакта на струите на разпръсквателя с чувствителни части на тялото (напр. очите). Между разпръсквателя и тялото трябва да се спазва достатъчно разстояние.
- ⚠ Продуктът не бива да се използва като дръжка. Трябва да се монтира отделна дръжка.
- ⚠ Големите разлики в налягането между изводите за студената и топлата вода трябва да се изравняват.

УКАЗАНИЯ ЗА МОНТАЖ

- / Преди монтажа продуктът трябва да се провери за транспортни щети. След монтажа не се признават транспортни или повърхностни щети.
- / Тръбопроводите и арматурата трябва да се монтира, промият и проверят в съответствие с валидните норми.
- / Трябва да бъдат спазвани валидните в съответните страни предписания за инсталиране.
- / Опакованото заедно с разпръсквателя уплътнение с цедка трябва да се монтира, за да се избегне натрупване на замърсявания от водопроводната мрежа. Натрупването на замърсявания може да наруши функцията и/или да доведе до увреждания на функционалните части на разпръсквателя, Hansgrohe не носи отговорност за получените се по този начин щети.

ТЕХНИЧЕСКИ ДАННИ

Работно налягане:	макс. 1 МПа
Препоръчително работно налягане:	0,1 - 0,5 МПа
Контролно налягане:	1,6 МПа
	(1 МПа = 10 bar = 147 PSI)
Температура на горещата вода:	макс. 70°C
Препоръчителна температура на горещата вода:	65°C
Термична дезинфекция:	макс. 70°C/4 мин

- / Самозащитен против обратно изтичане
- / Продуктът е разработен само за питейна вода!



МОНТАЖ (вижте стр. 31)

ОПИСАНИЕ НА СИМВОЛИТЕ



Не използвайте силикон, съдържащ оцетна киселина!



РАЗМЕРИ (вижте стр. 33)



Свободно стояща вана с външна обшивка.



ДИАГРАМА НА ПОТОКА (вижте стр. 34)

- ① Ръчен разпръсквател
- ② Изходящ накрайник



ПОЧИСТВАНЕ (вижте стр. 38)



ПОДДРЪЖКА (вижте стр. 36)

/ Съгласно DIN EN 1717 функционирането на приспособленията за предотвратяване на обратния поток трябва редовно да се проверява в съответствие с националните или регионални изисквания (поне веднъж годишно).



ОБСЛУЖВАНЕ (вижте стр. 35)



СЕРВИЗНИ ЧАСТИ (вижте стр. 37)

СПЕЦИАЛНИ ПРИНАДЛЕЖНОСТИ (не се съдържа в обема на доставка)



/ Удължител 60 mm #97686000 (вижте стр. 37)



/ Удължител 60 mm #10981000 (вижте стр. 37)



/ Удължител 20 mm #10983000 (вижте стр. 37)



/ Монтажен ключ #58085000 (вижте стр. 32+37)

△ UDHËZIME SIGURIE

- △ Për të evituar lëndimet e pickimeve ose të prerjeve gjatë procesit të montimit duhet që të vishni doreza.
- △ Produkti duhet të përdoret vetëm qëllimet e banjave, të higjienës dhe të larjes së trupit.
- △ Fëmijët dhe të rriturit me aftësi të kufizuara fizike, mendore dhe/ose ndijuese nuk duhet ta përdorin produktin pa qenë nën mbikëqyrje. Personat që janë nën ndikimin e drogave ose të alkoolit nuk duhet ta përdorin produktin.
- △ Kontakti i valëve të dushit me pjesët e ndjeshme të trupit (p.sh. me sytë) duhet që të shmanget. Midis dushit dhe trupit duhet që të mbahet një distancë e mjaftueshme.
- △ Produkti nuk duhet të përdoret si dorëze mbajtëse. Duhet të montohet një dorëzë mbajtëse e veçantë
- △ Ndryshimet e mëdha të presionit mes lidhjeve të ujit të ftohtë dhe atij të ngrohtë duhen ekuilibruar.

UDHËZIME PËR MONTIMIN













- / Përpara montimit duhet që produkti të kontrollohet për dëmtime nga transporti. Pas instalimit nuk do të njihet asnjë dëmtim nga transporti ose dëmtim i sipërfaqes.
- / Tubacionet dhe rubinetet duhet që të montohen, të shpëlahen dhe të kontrollohen sipas standardeve në fuqi
- / Duhet të respektohen linjat udhëzuese të instalimit, të vlefshme për vendet respektive.
- / Sita që i kemi bashkëngjitur spërkatëses duhet përdorur për të evituar thithjen e papastërtive nga rrjeti i ujësjellësit. Ndotjet mund të dëmtojnë pjesë funksionale të spërkatëses. Hansgrohe nuk Merr përgjegjësinë për dëmet e shkaktuara në këtë mënyrë.

TË DHËNA TEKNIKE

Presioni gjatë punës	maks. 1 MPa
Presioni i rekomanduar:	0,1 - 0,5 MPa
Presioni për provë:	1,6 MPa
	(1 MPa = 10 bar = 147 PSI)
Temperatura e ujit të ngrohtë	maks. 70°C
Temperatura e rekomanduar e ujit të ngrohtë:	65°C
Dezinfektim Termik:	maks. 70°C / 4 min

- / Siguresa kundër rrjedhjes në drejtim të kundërt
- / Produkti është projektuar ekskluzivisht për ujë të pijshëm!

PËRSHKRIMI I SIMBOLIT

-  Mos përdorni silikon që në përbërje ka acid acetik.
-  PËRMASAT (shih faqen 33)
-  Vaskë që qëndron e pavarur, e veshur nga jashtë.
-  DIAGRAMI I QARKULLIMIT (shih faqen 34)
 - ① Spërkatësja e dorës
 - ② Dalja
-  PASTRIMI (shih faqen 38)
-  MIRËMBAJTJA (shih faqen 36)
 - / Penguesit e rrjedhjes në drejtim të kundërt duhen kontrolluar rregullisht në bazë të normave DIN EN 1717 konform normave nacionale dhe regionale (së paku një herë në vit).
-  PËRDORIMI (shih faqen 35)
-  PJESËT E SERVISIT (shih faqen 37)
- PAJISJE TË POSAÇME (nuk përfshihet në vëllimin e furnizimit)
 -  / Zgjatës 60 mm #97686000 (shih faqen 37)
 -  / Zgjatës 60 mm #10981000 (shih faqen 37)
 -  / Zgjatës 20 mm #10983000 (shih faqen 37)
 -  / Çelësi i montimit #58085000 (shih faqen 32+37)



MONTIMI (shih faqen 31)

وصف الرمز

هام! لا تستخدم السليكون الذي يحتوي على أمحاض!



أبعاد (راجع صفحة 33)



حوض استحمام (بانيو) منفصل بغطاء خارجي.

رسم للصرف (راجع صفحة 34)



① الدش اليدوي
② الصنبور في

التنظيف (راجع صفحة 38)



الصيانة (راجع صفحة 36)



/ يجب فحص صمام عدم الرجوع بصفة منتظمة حسب المواصفة DIN EN 1717 وذلك طبقاً للوائح الوطنية أو الإقليمية (مرة واحد سنوياً على الأقل).

التشغيل (راجع صفحة 35)



قطع الغيار (راجع صفحة 37)



ملحقات خاصة

(غير مدرج مع المحتويات المسلمة)

/ وصلة إطالة 60 #97686000 mm (راجع صفحة 37)



/ وصلة إطالة 60 #10981000 mm (راجع صفحة 37)



/ وصلة إطالة 20 #10983000 mm (راجع صفحة 37)



/ مفتاح التركيب #58085000 (راجع صفحة 37+32)



تنبيهات الأمان

△ يجب إرتداء قفازات الليد أثناء التركيب لتجنب حدوث أخطار الإنحشار أو الجروح.

△ لا يجب استخدام المنتج إلا في أعراض الاستحمام والأعراض الصحية وأعراض تنظيف الجسم.

△ لا يسمح لأي أطفال أو أفراد بالغين يعانون من إعاقات بدنية أو ذهنية أو حسية أو يعانون من جميع هذه الإعاقات باستخدام المنتج إلا تحت إشراف آخرين. كما أنه لا يسمح لأي شخص تحت تأثير تناول الكحول أو المخدرات باستخدام نظام الدش.

△ يجب تجنب حدوث إتصال مباشر بين الماء الخارج من رأس الدش وبين أجزاء الجسم الحساسة (مثل العينين). يجب وجود مسافة كافية بين رأس الدش والجسم.

△ ممنوع إستخدام المنتج كمقبض. يجب تركيب مقبض منفصل.

△ يجب أن يكون تيار الماء الساخن والماء البارد متعادلين في الضغط.

تعليمات التركيب

/ قبل القيام بعملية التركيب، يجب فحص المنتج للتأكد من خلوه من أية تلفيات ناتجة عن النقل. بعد القيام بعملية التركيب، لن يتم الاعتراف بوجود أية تلفيات سطحية أو تلفيات ناتجة عن عملية النقل.

/ يجب تركيب وغسيل واختبار التوصيلات وخلطات المياه طبقاً للمعايير السارية.

/ يجب مراعاة القواعد الخاصة بالتركيب وأعمال السباكة وفقاً للوائح الخاصة بكل بلد.

/ يجب إدخال الحلقة الشبكية لحماية الدش اليدوي من الأوساخ التي تحملها شبكة المواسير. حيث تؤدي الأوساخ الواردة إلى حدوث أعطال أو / وقد تتسبب في تلف أجزاء من من الدش، ومثل هذه الأعطال تلغي كافة المطالبات الخاصة بالمسؤولية أو الضمان.

المواصفات الفنية

ضغط التشغيل: الحد الأقصى 1 ميجاباسكال

ضغط التشغيل الموصى به: 0,5 - 0,1 ميجاباسكال

ضغط الاختبار: 1,6 ميجاباسكال

(1 ميجاباسكال = 10 بار = 147 PSI)

درجة حرارة الماء الساخن: الحد الأقصى 70°C

درجة الحرارة الموصى بها للماء الساخن: 65°C

تعقيم حراري: الحد الأقصى 4/70°C الدقيقة

/ خاصية عدم التدفق العكسي

/ المنتج مخصص فقط لماء الشرب!

التركيب (راجع صفحة 31)



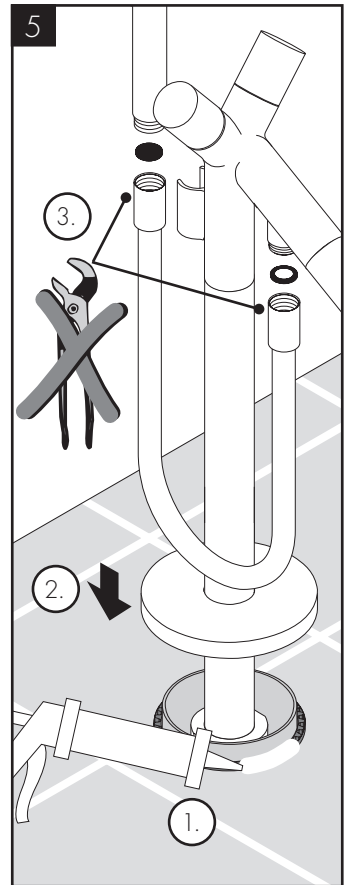
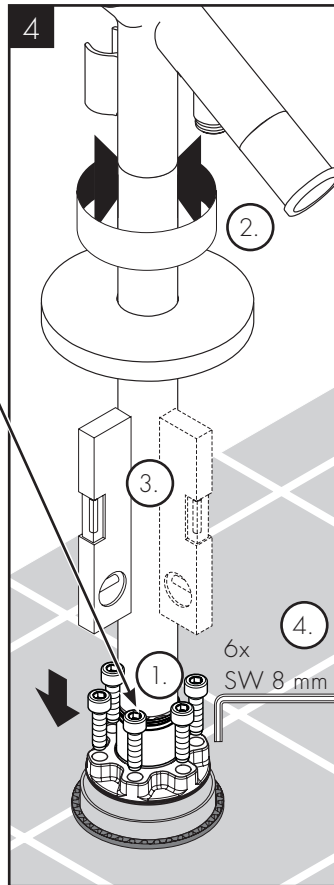
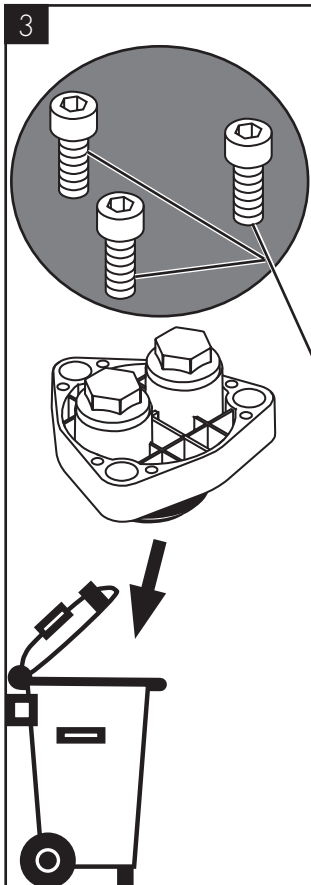
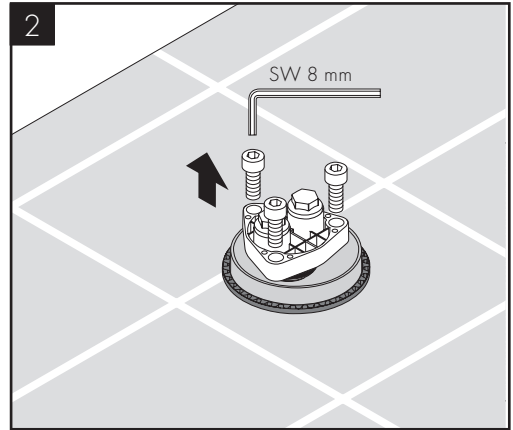
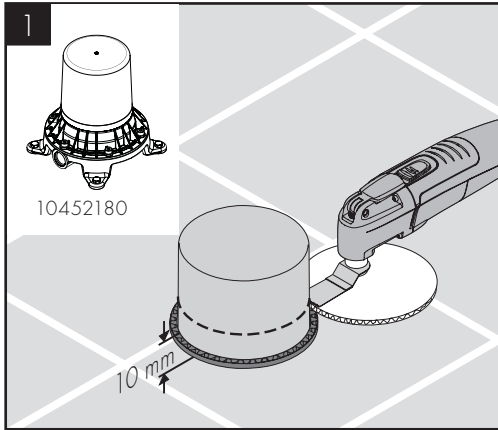

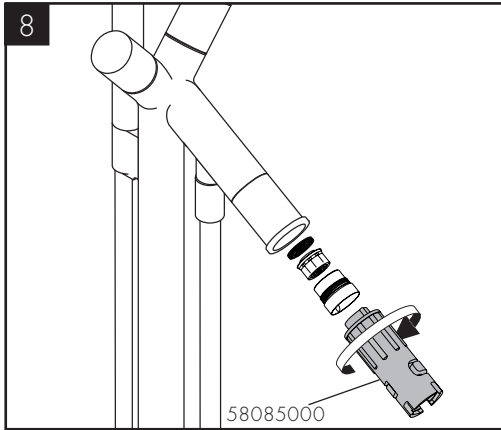
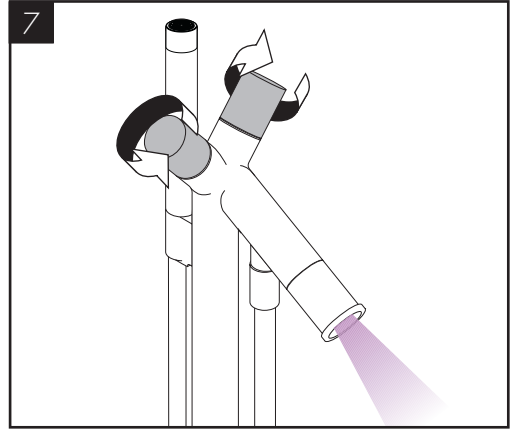
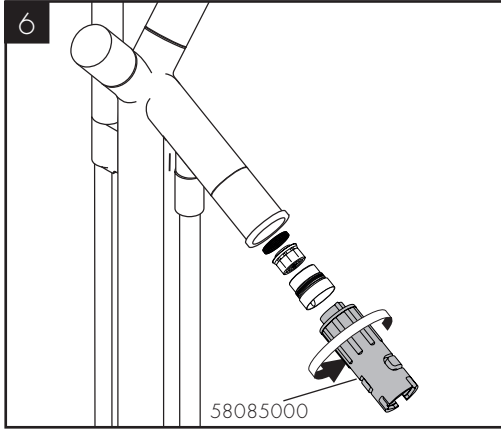



AXOR Starck 10458000

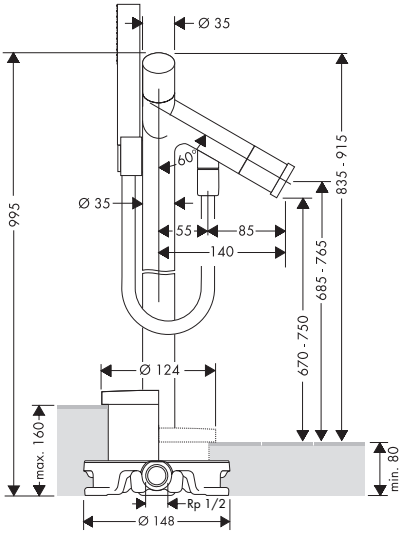

AXOR Starck 28532000

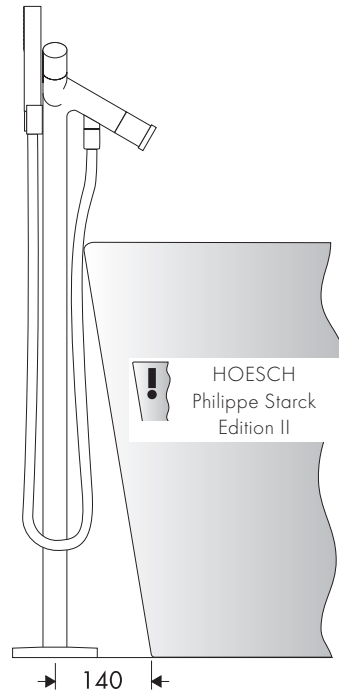
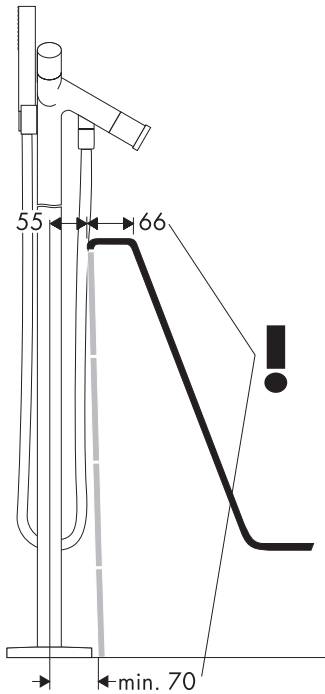
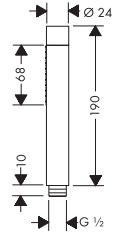

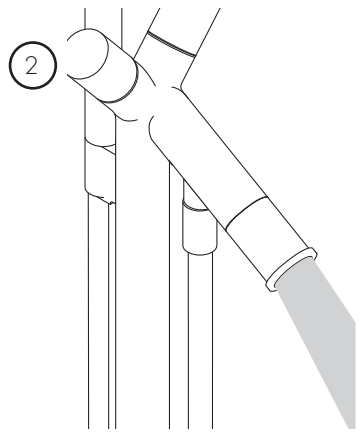
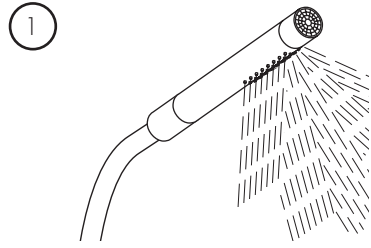
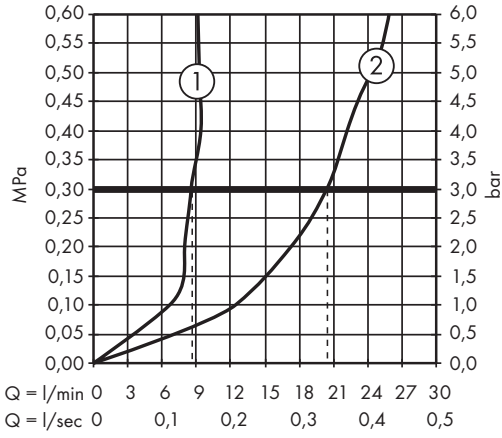

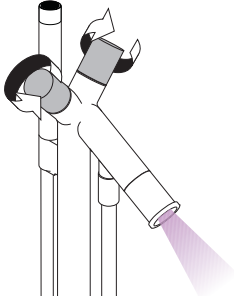

öföfen / ouvert / open / aperto / abierto / open / åbne / abrir / otworzyć / otevřít / otvorit / 开 / откpыть / nyitás / avaaminen / öpna / atidaryti / Отваранje / açmak / deschide / ανοικτό / odpreti / avage / atvērt / otvoriť / åpne / отваряне / hare / فتح

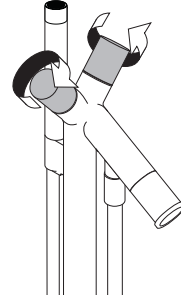

schließen / fermé / close / chiudere / cerrar / sluiten / lukke / fechar / zamknąć / zavřít / uzavriť / 关 / закрыть / bezárás / sulkeminen / stänga / uždaryti / Zatvaranje / kapatmak / închide / κλειστό / zapreti / sulgege / aizvērt / zatvoriť / lukke / затваряне / mbylle / إغلاق!

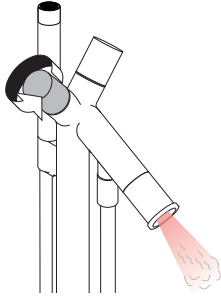

warm / chaud / hot / caldo / caliente / warm / varmt / quente / ciepła / teplá / teplá / 热 / горячая / meleg / lämmin / varmt / karštas / Vruća voda / sıcak / cald / ζεστό / toplo / kuum / karsts / topla / varm / тепло / i ngrohtë / ساخن

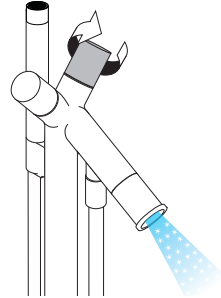

kalt / froid / cold / freddo / frío / koud / koldt / fria / zimna / studená / studená / 冷 / холодная / hideg / kylmä / kallt / šaltas / Hladno / soğuk / rece / κρύο / mrzlo / külm / auksts / hladno / kaldt / студено / i ftohtë / بارد

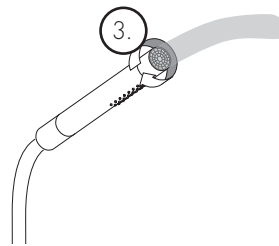
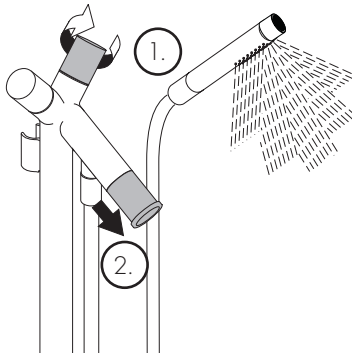

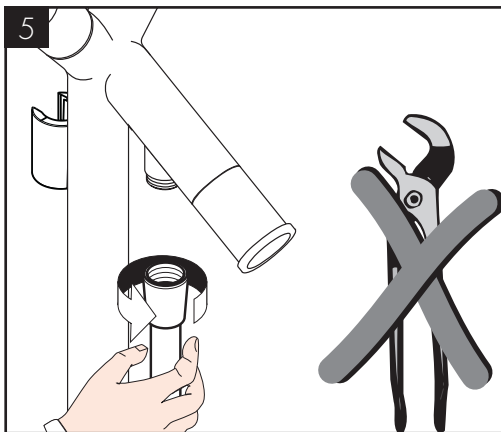
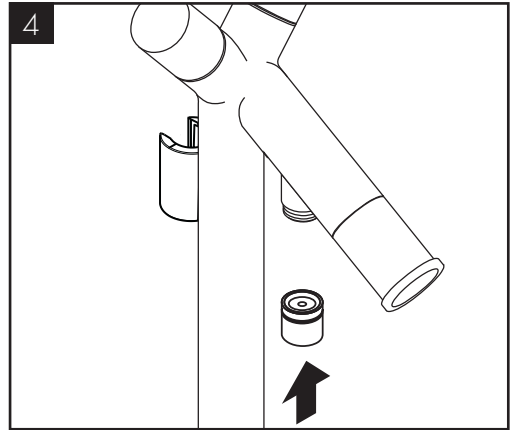
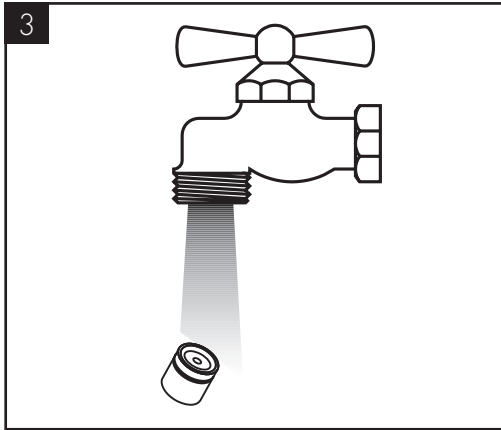
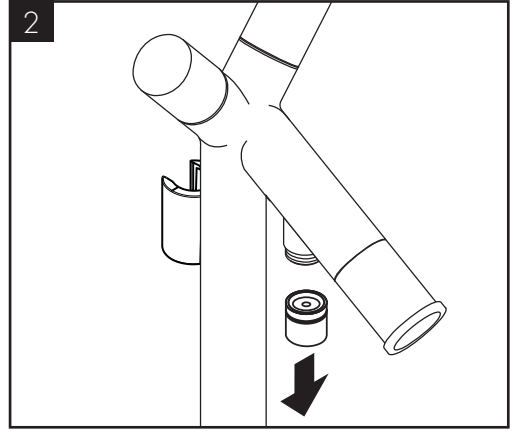
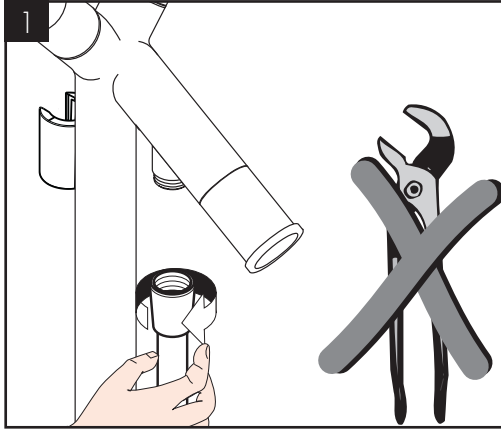

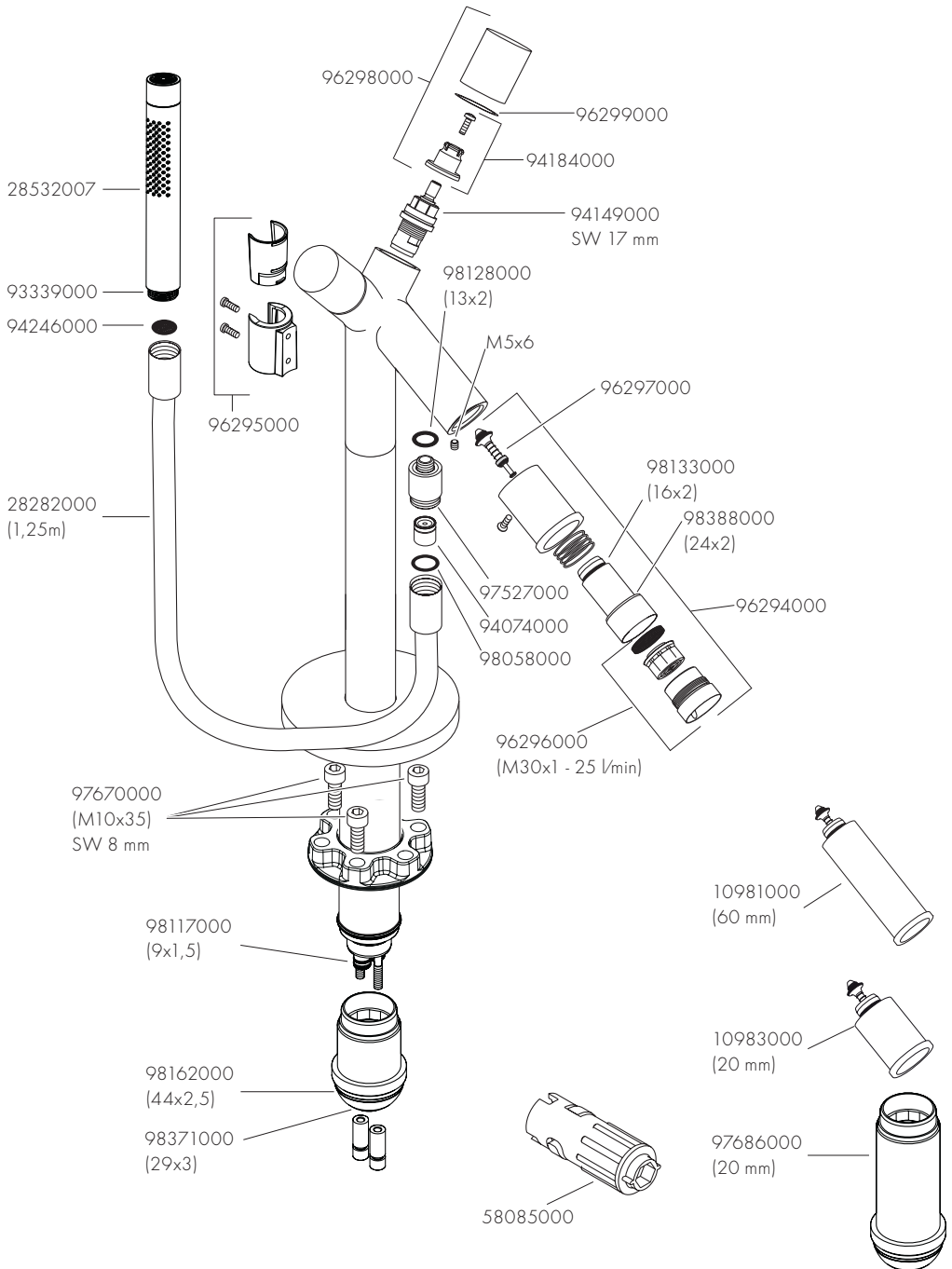



- DE / Reinigungsempfehlung / Garantie / Kontakt
FR / Recommandation pour le nettoyage / Garanties / Contact
EN / Cleaning recommendation / Warranty / Contact
IT / Raccomandazione di pulizia / Garanzia / Contatto
ES / Recomendaciones para la limpieza / Garantía / Contacto
NL / Aanbevelingen inzake reiniging / Garantie / Contact
DK / Rensning, anbefaling / Garanti / Kontakt
PT / Recomendações de limpeza / Garantia / Contacto
PL / Zalecenie dotyczące pielęgnacji / Gwarancja / Kontakt
CS / Doporučení k čištění / Záruka / Kontakt
SK / Odporúčania pre čistenie / Záruka / Kontakt
ZH / 清洁指南 / 担保 / 接触
RU / Рекомендации по очистке / Гарантия / Контакты
HU / Tisztítási tanácsok / Garancia / érintkezés
FI / Puhdistussuositus / Takuu / Kosketus
SV / Rengöringsrekommendationer / Garanti / Contacto
LT / Valymo rekomendacijos / Garantija / Kontaktai
HR / Preporuke za čišćenje / Garancija / Kontakt
TR / Temizleme önerisi / Garanti / Temas
RO / Recomandări pentru curățare / Garanție / Contact
EL / Σύσταση καθαρισμού / Εγγύηση / επαφή
SL / Priporočilo za čišćenje / Garancija / Kontakt
ET / Puhastussuovitused / Garantii / Kontakt
LV / Tīrīšanas ieteikumi / Garantija / Kontakti
SR / Preporuke za čišćenje / Garancija / Kontakt
NO / Anbefaling for rengjøring / Garanti / Kontakt
BG / Препоръка за почистване / Гаранция / Контакт
SQ / Këshilla rreth pastrimit / Garancia / Kontakt
KO / 세정시 권장사항 / 품질보증 / 접촉
AR / توصيات التنظيف / الضمان (الولايات المتحدة الأمريكية) / اتصال



[www.axor-design.com/
cleaning-recommendation](http://www.axor-design.com/cleaning-recommendation)



[www.axor-design.com/
cleaning-recommendation](http://www.axor-design.com/cleaning-recommendation)



[www.axor-design.com/
cleaning-recommendation](http://www.axor-design.com/cleaning-recommendation)



[www.axor-design.com/
cleaning-recommendation](http://www.axor-design.com/cleaning-recommendation)

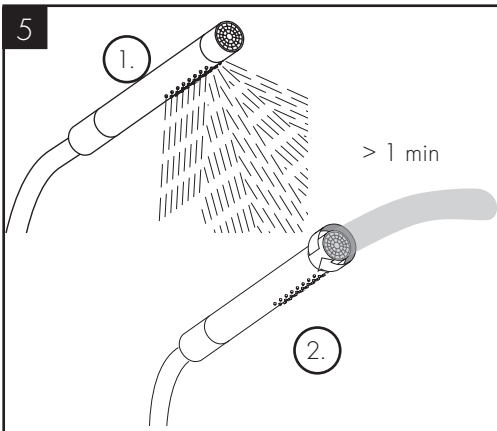
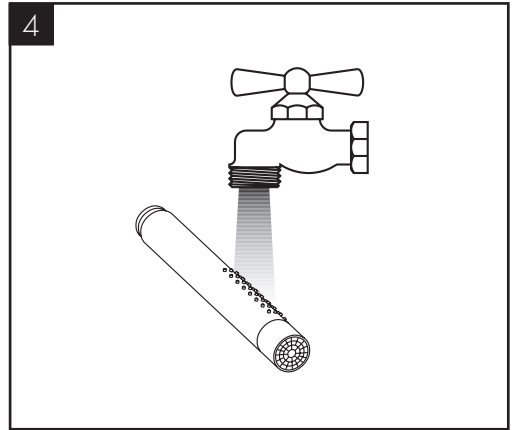
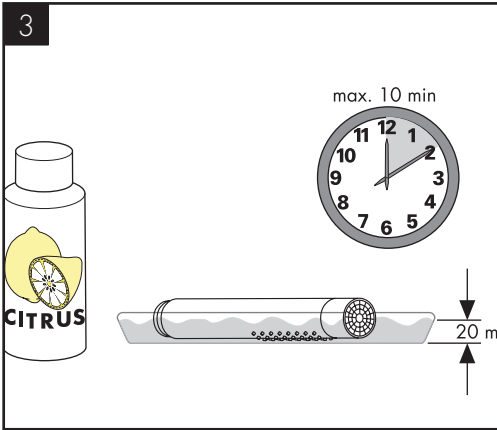
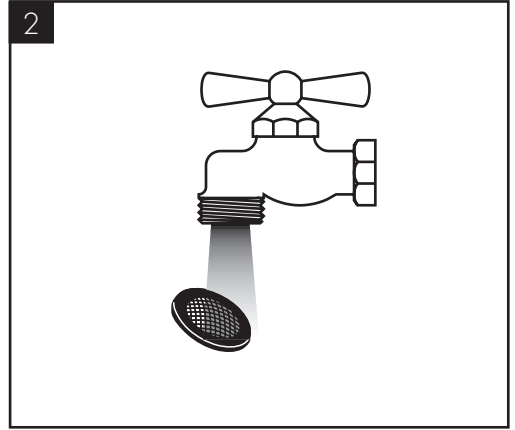
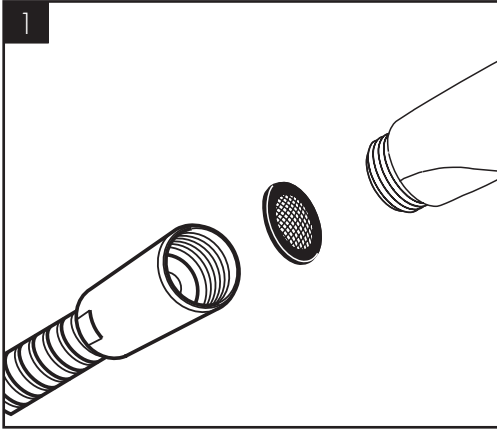

AXOR

AXOR / Hansgrohe SE
Austraße 5-9
77761 Schiltach
Deutschland

info@axor-design.com
axor-design.com

11/2018
9.08375.03